

Classification System for Semi-Rigid Beam-to-Column Connections

Abstract

The current study attempts to recognise an adequate classification for a semi-rigid beam-to-column connection by investigating strength, stiffness and ductility. For this purpose, an experimental test was carried out to investigate the moment-rotation ($M-\theta$) features of flush end-plate (FEP) connections including variable parameters like size and number of bolts, thickness of end-plate, and finally, size of beams and columns. The initial elastic stiffness and ultimate moment capacity of connections were determined by an extensive analytical procedure from the proposed method prescribed by ANSI/AISC 360-10, and Eurocode 3 Part 1-8 specifications. The behaviour of beams with partially restrained or semi-rigid connections were also studied by incorporating classical analysis methods. The results confirmed that thickness of the column flange and end-plate substantially govern over the initial rotational stiffness of flush end-plate connections. The results also clearly showed that EC3 provided a more reliable classification index for flush end-plate (FEP) connections. The findings from this study make significant contributions to the current literature as the actual response characteristics of such connections are non-linear. Therefore, such semi-rigid behaviour should be used to for an analysis and design method.

Keywords

Beam-to-column connection; semi-rigid; flush end-plate connection; moment-rotation curve.

Iman Faridmehr ^a

Mamood Md. Tahir ^a

Tom Lahmer ^b

^a UTM Construction Research Centre (CRC), Institute of Smart Infrastructures and Innovative Construction, Universiti Teknologi Malaysia (UTM), Skudai, Johor Bahru, 81300, Malaysia

^b Institute of Structural Mechanics-Structural Analysis and Component Strength, Bauhaus-University Weimar, Germany

Corresponding author: Mahmood Md.

Tahir mahmoodtahir@utm.my

Fax: +60-7-5531935

Tel: +60-7-5531934

<http://dx.doi.org/10.1590/1679-78252595>

Received 07.11.2015

In revised form 14.05.2016

Accepted 17.06.2016

Available online 10.06.2016

1 INTRODUCTION

Two extreme cases regarding the actual performance of beam-to-column connections have been idealised in traditional analysis and design of steel frame structures. One extreme is known as rigid-joint connection while the other one is referred to as pinned-joint connection. Nevertheless, both of such idealised models do not accurately present the actual behaviour since most of the connections demonstrate a semi-rigid behaviour. Moreover, non-conservative predictions regarding the structural drift

or frame stability could result from such approaches. Thus, real connections in steel frames should be treated as ‘semi-rigid’ ones. In both specifications for structural steel buildings, ANSI/AISC 360-10 (ANSI/AISC 360-10 2010) and Eurocode 3 Part 1-8 specification (Eurocode 3 - Part 1-8 2005), three types of connections are classified: Type 1-rigid connection; Type 2-simple connection; and Type 3-semi-rigid connection. The fundamental criteria considered in categorising connections is that the most significant behavioural appearances are exhibited by a moment-rotation ($M-\theta$) curve. From this point of view, such classifications directly explain strength, stiffness and ductility of connections. The secant stiffness, K_S , at service load is considered as an index property of connection stiffness (ANSI/AISC 360-10 2010),

$$K_s = M_s/\theta_s \quad (1)$$

where,

M_s = moment at service loads, (kN-m)

θ_s = rotation at service loads, rad

Devising criteria suitable for serviceability and ultimate limit states design is regarded as one of the main difficulties in the provision of a classification system. For serviceability, deformation and other stiffness-related characteristics of the connections are known to be the prime considerations. Yet, in the case of ultimate limit states, strength parameters would be the major considerations. The maximum moment developed by a connection, M_n , is known as the strength of a connection (Figure 1). Ductility, maximum rotation capacity, θ_u , and energy absorption are believed to be the critical factors for structures located in seismic areas, however.

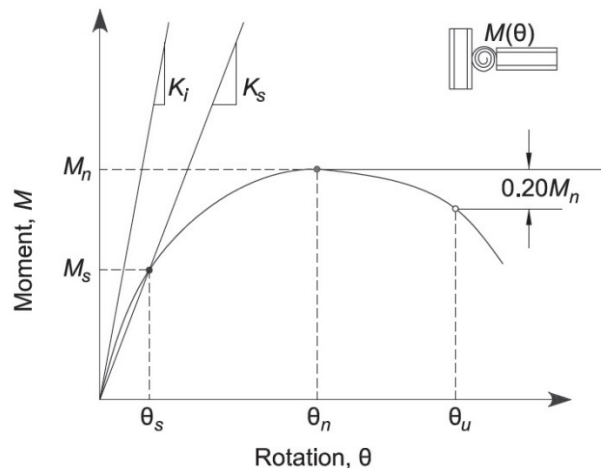

Figure 1: Strength, stiffness and ductility characteristics of the moment-rotation response of a partially restrained connection (ANSI/AISC 360-10 2010).

Over the past few decades, efforts have been made regarding connections classification and their influence on structural response within the structural engineering profession (Reidar Bjorhovde *et al.* 1990; Wai-Fah Chen & N Kishi 1989; N Kishi *et al.* (1997); DA Nethercot *et al.* 1998). These analyses mainly involve the calculation of the moment-rotation curve ($M-\theta$), which is calculated via the finite

element (FE) method. In the experimental tests, initial stiffnesses and complete moment-rotation curves were reported for different connections i.e. top and seat flange angles, double web angles and end-plate with varying dimensions (Atorod Azizinamini & James B Radzinski 1989; Ana M Girao Coelho & Frans SK Bijlaard 2007). The geometric parameters that most significantly affect moment-rotation behaviour were determined such as thickness of end-plate and thickness of top and seat flange angles. The data are compared to analytical models for predicting the initial stiffness and complete nonlinear moment-rotation relationships for the connections. Based on these studies the boundary between rigid and semi-rigid connections is established by taking into account the elastic-plastic behaviours at the serviceability limit state along with the ultimate limit state. Furthermore, the required rotational boundary was suggested for the connections classified as rigid.

There is a large volume of published work on semi-rigid connections indicating that this interest is being maintained and even expanded more and more (E Bayo *et al.* 2006; SW Jones *et al.* 1983; SW Jones *et al.* 1980; ME Kartal *et al.* 2010; Sang-Sup Lee & Tae-Sup Moon 2002; LMC Simoes 1996). These studies mostly deal with the effect of semi-rigid connections on the structural performance of steel structures. The finding of these studies suggest that adequately designed semi-rigid beam-to-column connections and frames will associated with ductile and steady hysteretic performance. The results also revealed that there was a direct relationship between connection stiffness and base shear however, the lateral drift did not decrease linearly by increasing connection stiffness. Finally, the finding highlights that ideal structure should incorporate the least probable base shear reaction with satisfactory lateral sway.

Recently, Díaz *et al.* (Concepción Díaz *et al.* 2012) proposed a novel methodology for the optimal design of semi-rigid steel connections incorporating meta-models generated with Kriging and Latin Hypercube. Two examples including bolted extended end-plate connections were applied in the aforementioned methodology. An efficient analysis procedure of 3D semi-rigid steel frames is proposed by Nguyen and Kim (Phu-Cuong Nguyen & Seung-Eock Kim 2014). In their study, beam-to-column connections were developed by 3D nonlinear spring elements for considering spread-of-plasticity effects. Response of partially-restrained bolted beam-to-column connections under cyclic loads was evaluated by Brunesi *et al.* (E Brunesi *et al.* 2014). They concluded that the efficiency of these joints in contributing to the energy absorption were limited due to low-cycle during large displacement. Examples of full-scale moment resisting connection systems were numerically evaluated, concentrating on bottom and seat angle elements that are believed to govern the global behaviour of the connection in terms of failure mode, ductility capacity and dissipation energy capacities of the whole structure.

In prior studies, researchers defined the connection classification index, which was mainly extracted from moment-rotation ($M-\theta$) curves. The findings from these studies make major contributions to the current ANSI/AISC 360-10, and Eurocode 3 Part 1-8 specification. However, some differences exist among these two specifications in terms of connection classification schemes, although the findings are somewhat contradictory. Literature reviews indicated that there are no controlled studies that compare connection classification criteria between these two specifications. The current study attempts to investigate an adequate beam to column connection classification index from ANSI/AISC 360-10 (ANSI/AISC 360-10 2010), and Eurocode 3 Part 1-8 specification (Eurocode 3 - Part 1-8 2005) through test results of FEP for semi-rigid connections.

2 CONNECTION RESPONSE CONSIDERATIONS

Connection response based on gravity loading on the performance behaviour of the beam with flexible or semi-rigid connections is essential to be investigated. By considering a classical method like slope-deflection for a beam segment with rotation at each end, the moment on end A is defined as shown in Figure 2 and Equation (2).

$$M_A = \frac{4EI}{L}\theta_A + \frac{2EI}{L}\theta_B \quad (2)$$

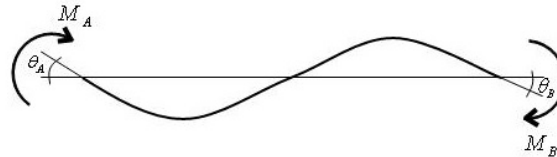

Figure 2: Beam with end moment and end rotation.

For a fixed-end beam with uniform gravity loading, Figure 3, the end moment is defined as Equation (3).

$$FEM_A = -\frac{Wl^2}{12} \quad (3)$$

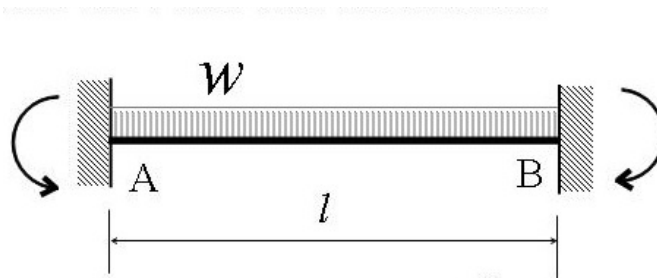

Figure 3: Fixed-end beam with uniform load.

The rotation at B is equal and opposite of the rotation at A. Accordingly, by superimposing Equations. (2) and (3), the moment at A is defined as shown in Equation (4).

$$M_A = \frac{2EI}{L}\theta - \frac{wl^2}{12} \quad (4)$$

Two special cases, namely, simple and fixed-end beam, are investigated here. In simple beam condition, the moment at A is zero and by solving Equation (4), the rotation is calculated as follows:

$$0 = \frac{2EI}{L}\theta - \frac{wl^2}{12} \quad \rightarrow \quad \theta = \frac{Wl^3}{24EI} \quad (5)$$

For a fixed-end beam, by considering the rotation equal to zero, the moment at A is calculated as follows:

$$M_A = \frac{2EI}{L}(0) - \frac{wl^2}{12} \quad \rightarrow \quad M_A = -\frac{wl^2}{12} \quad (6)$$

Eqs. (5) and (6) are plotted in Figure 4. This Figure clearly highlights the linear relationship between the rotation and moment at the end of the beam.

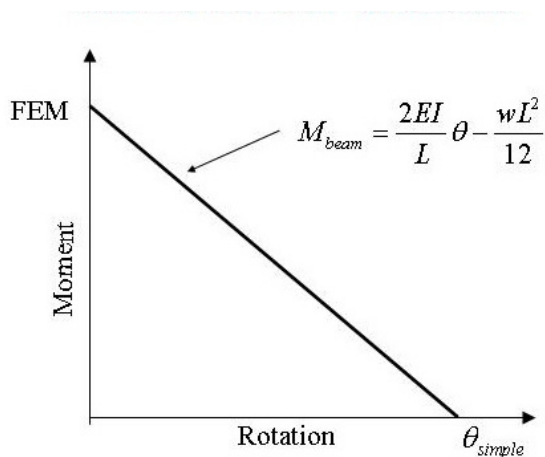

Figure 4: Moment versus rotation of the beam.

The moment at the connection is related to the connection stiffness and rotation as shown in Figure 5 and Equation (7).

$$M_{conn} = -n\theta \quad (7)$$

where,

n is connection rotational stiffness

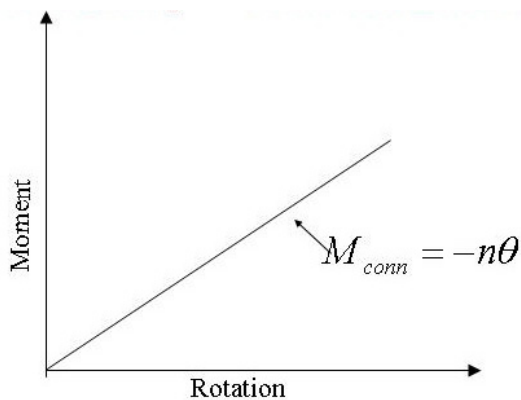

Figure 5: Moment versus rotation of connection.

Figure 5 shows that the moment-rotation diagram is represented as a straight line. However, this linear behaviour is associated with some assumptions. Figure 6 shows the real behaviour of double angle-web connections which is an indication of semi-rigid connections. Referring to this Figure, the connection does not behave linearly similar to that of Figure 5. Also, at some particular point, the connection experiences failure.

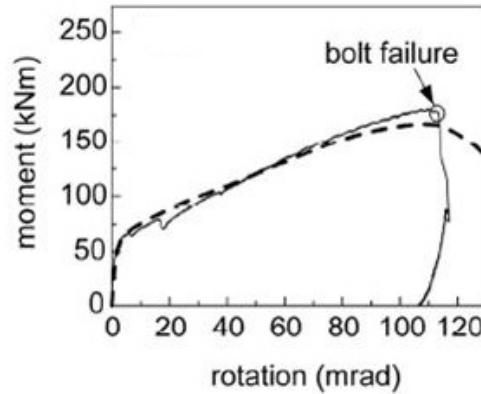

Figure 6: Real flush end-plate connection curve.

In case of superimposing the beam and connection curves, the equilibrium shown in Figure 7 is derived.

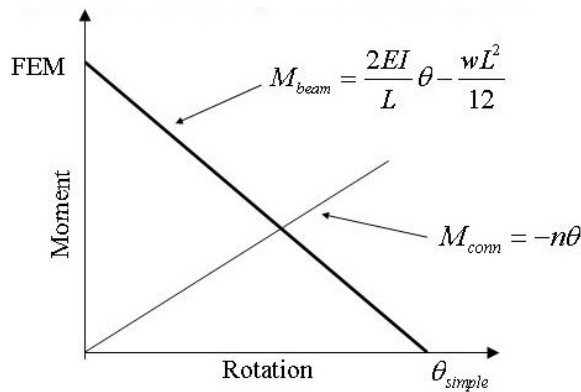

Figure 7: Superimpose of beam line and connection line.

By setting Equations. (4) and (7) equal, the rotation at the point of equilibrium can be determined by the following equation:

$$M_{conn} = M_{beam} \rightarrow -n\theta = \frac{2EI}{L}\theta - \frac{wl^2}{12} \rightarrow \theta = \frac{1}{\left[1 + \frac{nL}{2EI}\right]} \left[\frac{wl^3}{24EI}\right] \quad (8)$$

Similarly, the moment at the point of equilibrium can be determined as follows:

$$\theta_{conn} = \theta_{beam} \rightarrow \theta_{conn} = \frac{-M_{conn}}{n} \rightarrow \theta_{beam} = \frac{\left[M_{beam} + \frac{wL^2}{12}\right]}{\frac{2EI}{L}} \tag{9}$$

$$\rightarrow M_{conn} = M_{beam} = M = \frac{1}{\left[1 + \frac{2EI}{nL}\right]} \left[-\frac{wL^2}{12}\right]$$

In the above mentioned equation, $\frac{(EI)}{n}$ is the ratio of the beam stiffness to the connection stiffness. This ratio, u, is defined as follows:

$$u = \frac{\left(\frac{EI}{L}\right)}{n} = \frac{EI}{nL} \tag{10}$$

If this definition is substituted with Equation (9) for the connection moment, the moment on the end of the beam, the Equation (11) can be derived:

$$M_{conn} = \frac{-wL^2/12}{(2u + 1)} \tag{11}$$

If a uniformly loaded beam is considered and Equation (9) is solved for the moment at the centre line of the beam, Equation (12) can be derived:

$$M_{pos} = \left(\frac{6u + 1}{4u + 2}\right) \left(\frac{wL^2}{12}\right) \tag{12}$$

Equations. (11) and (12) are plotted in Figure 8 for linear flexible connections subjected to gravity uniform loading. Figure 8 shows that the connection moment or negative moment starts out when the stiffness ratio, u, is zero, whereas the moment over the fixed-end moment ratio is 1. When the stiffness ratio increases, the moment on the end of the beam decreases. This Figure also demonstrates that while the moment on the end of the beam decreases, the moment on the centre line increases simultaneously. It is worth mentioning that at u equal to zero, we have $\frac{wL^2}{12}$ at the end and $\frac{wL^2}{24}$ at the centreline. Moreover, as u increases, the centreline moment goes up, whereas at the u of infinity, the end moment is expected to be zero and the centreline moment is expected to be $\frac{wL^2}{8}$, around one and half times the fixed-end moment.

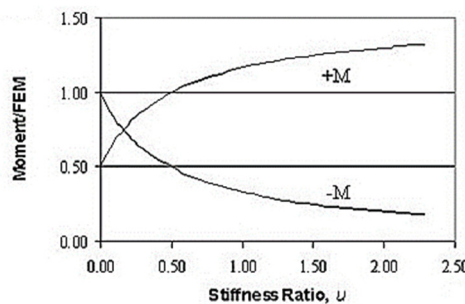

Figure 8: Beam response to flexible connections.

Three different connection curves representative of fully-restrained, partially-restrained and simple shear connections combined by beam line are shown in Figure 9. By superimposing the beam line, one could assess whether this behaviour is sufficiently close to rigid or pin. It can be inferred from Figure 9 that as long as the connection could resist at least 90 per cent of the fixed-end moment, it could be classified as rigid. Yet, the other end indicates that as long as the connection does not take more than 20 percent of the fixed-end moment, it could be classified as simple. Any behaviour between these two points is considered a partially-restrained connection.

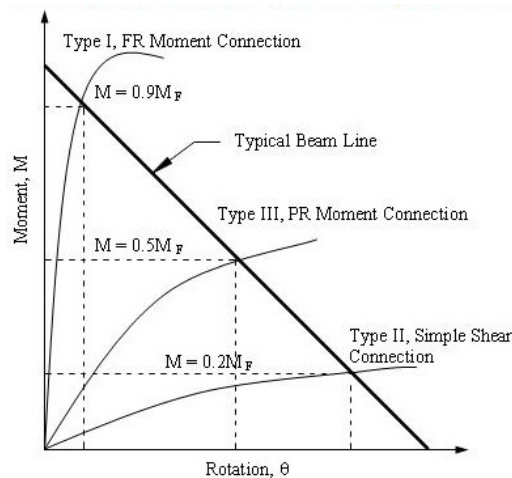

Figure 9: Beam and connections equilibrium using connection curve.

Figure 10 shows superimposing the straight line of fully-restrained, partially-restrained and simple shear connection to the beam line. As shown in this Figure, if we take the straight line up to 90, 50 and 20 percent of the fixed-end moment, the relationship of $\frac{k_s L}{EI}$ could be determined as fully rigid, semi-rigid and simple connections, respectively. In these relationships, the secant stiffness of connection, k_s , is defined using Equation (1).

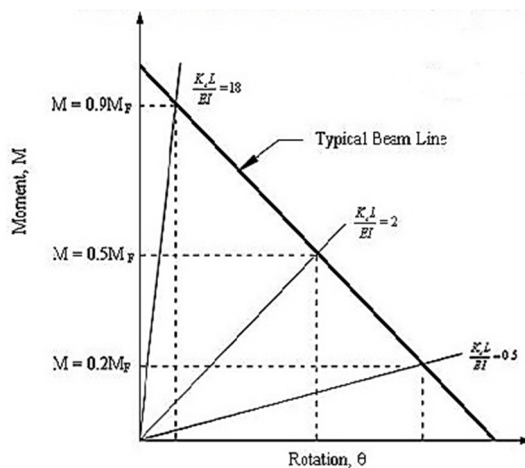

Figure 10: Beam and connections equilibrium using secant stiffness.

3 CONNECTION CLASSIFICATION SYSTEM BY AISC AND EUROCODE 3 SPECIFICATION

3.1 ANSI/AISC 360-10 Classification

Connection classification by AISC specification is conducted through modelling the most significant behavioural characteristics of the connection using a moment-rotation ($M-\theta$) curve. According to the AISC guideline, the ($M-\theta$) curve is defined as being a part of the column and beam as well as the connecting components. This is because the connection rotation in a physical test is basically identified over a length that takes not only the connecting elements contributions, but also connected beam and the column shear panel zone. In general, based on AISC specifications, such classifications explain stiffness, strength and ductility of the connections.

The secant stiffness, K_S , at service loads is considered a fundamental criteria of the connection stiffness as defined in Equation (1). If $\frac{k_s L}{EI} \geq 20$, the connection is considered to be fully-rigid or FR connections (be able to preserve the rotation between members). If $\frac{k_s L}{EI} \leq 2$, the connection is classified as simple (it rotates without increasing moment). The connection stiffness between these two boundaries is categorised as a partially restrained or semi-rigid connection, and the strength, stiffness and ductility of the connection should be taken into account in the analysis. Basically, there are differences between AISC classification and what we have found in the analytical calculation. This is summarised in Figure 10 as it considers the ratio of 18 and 0.5 for fully-restrained and simple shear connections, respectively.

The maximum moment can be carried out by connection introduced as M_n , as shown in Figure 11. If the ($M-\theta$) curve response does not demonstrate a peak moment, the moment at a rotation of 0.02 rad is considered the maximum strength of connection (S-H Hsieh & GG Deierlein 1991). Connections that convey less than 20% of the plastic moment of the connected beam, M_p , at a rotation of 0.02 rad, is supposed to have no flexural capacity for analysis. It is worth mentioning that for an FR connection, strength less than the beam strength is anticipated. Yet, it is also probable for a PR connection to provide a moment capacity higher than the connected beam.

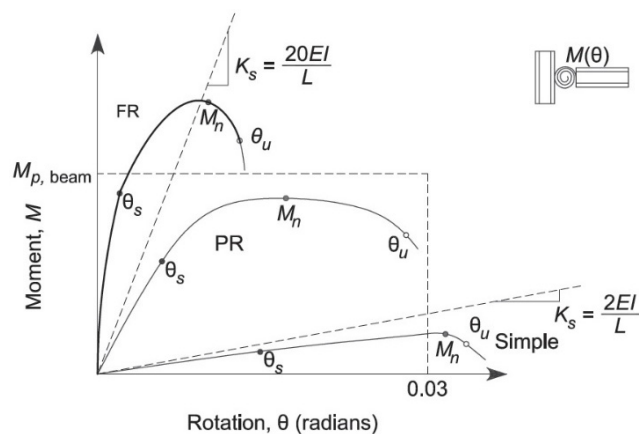

Figure 11: Classifications of moment-rotation response of fully restrained (FR), partially restrained (PR) and simple connections based on strength (ANSI/AISC 360-10 2010).

The required ductility of a connection is a function of its application. For instance, a lower ductility is required for a structure in a low-seismic zone compared to those located in high seismic zones. The structural system plays an important role in rotation ductility requirements for seismic design. Once the connection strength capacity considerably exceeds the plastic moment of the connected beam, the ductility of the whole structure is measured by the beam, and the connection is supposed to remain elastic. The connection may experience severe inelastic deformation where its strength capacity is marginally higher than the plastic moment of the connected beam. However, deformations may concentrate within the connection component if the beam flexural capacity surpasses the connection strength. According to Figure 11, the rotation capacity, ϑ_u , identified as the particular point where either the resisting moment has decreased to $0.8M_n$ or the connection has experienced deformation beyond 0.03 rad. This second principle is reliable for connections with no obvious decrease in strength capacity until a very large deformation occurs. An evaluation should be made among the rotation resistance, ϑ_u , and the required rotation strength where a 0.03-rad rotation resistance is considered acceptable. This amount is equal to the minimum connection capacity in conformity with seismic provisions for special moment frames (*Seismic Provisions for Structural Steel Buildings* 2010).

3.2 Eurocode 3 Part 1-8

In this specification, connections are classified by their stiffness and strength. A joint may be classified as rigid, nominally pinned or semi-rigid according to its rotational stiffness, by comparing its initial rotational stiffness, $S_{j,ini}$, with classification boundaries is given in Figure 12. Beam-to-column connections categorised as fully-rigid are supposed to have adequate rotational stiffness to consider analyses based on fully-rigid. In Figure 12, zone 1 represents as rigid connection and defined as in Equation (13).

$$S_{j,ini} \geq \frac{K_b EI_b}{L_b} \quad (13)$$

where,

K_b is taken as 8 for structures with lateral displacement of frames by at least 80%

K_b is taken as 25 for other frames

A nominally pinned joint should be capable of transmitting the internal forces, without developing significant moments that might adversely affect the members or the structure as a whole. According to Figure 12, connections are considered as nominally pinned, zone 3, if:

$$S_{j,ini} \leq \frac{0.5EI_b}{L_b} \quad (14)$$

The beam-to-column connections that do not address the criteria for FR connections or a simple connections shall be classified as a partially restrained (PR) or semi-rigid connections, zone 2. PR connections provide an anticipated deformation between connected members, based on the (M- ϑ) curve features of the connections. PR connections are supposed to convey the shear forces as well as bending moments.

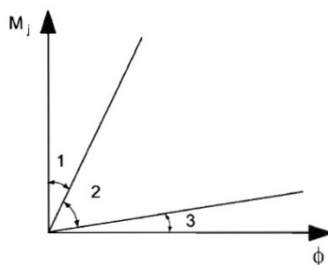

Figure 12: Classification of joints by stiffness according to Eurocode 3.

The initial rotational stiffness, $S_{j,ini}$, of a connection should be determined from the flexibility of its basic components; each is represented by an elastic stiffness coefficient, k_i . The initial rotational stiffness, $S_{j,ini}$, of a beam-to-column connection may be calculated with sufficient accuracy from:

$$S_j = \frac{Ez^2}{\mu \sum_i \frac{1}{k_i}} \tag{15}$$

where,

k_i is the stiffness coefficient for basic joint component i ;

z is the lever arm

μ is the stiffness ratio ($S_{j,ini}/S_j$)

Notice that the initial rotational stiffness, $S_{j,ini}$, of connections is given by expression (15) with $\mu = 1$. The basic components that should be taken into account for bolted end-plate connection are given in Table 1 in accordance with EC3.

Beam to Column Connection with Bolted End-plate Connections	Number of Bolt-rows in Tension	Stiffness Coefficient k_i to be Taken into Account
Single-side	One	$K1 ; k2; k3 ; k4 ; k5 ; k10$
	Two or more	$K1 ; k2; k_{eq}$

Table 1: Basic components of end-plate connections

A joint may be classified as full-strength, nominally pinned or partial strength by comparing its design moment resistance, M_n , with the design moment resistances of the members that it connects. A joint is categorised as simple if its design moment resistance, M_n , is not higher than 0.25 times the design moment resistance required for a fully-rigid connection and also addresses the adequate rotation capacity. The design capacity of a fully-rigid connection should not be less than the connected beam. A connection is classified as FR connections if it addresses the following equation:

$$M_n \geq M_p \tag{16}$$

where,

M_p is the design plastic moment resistance of the beam.

4 TEST RIG AND CASE STUDIES

In order to conduct a full-scale experimental test, a test rig was considered to accommodate a 3-metre-height column and a 1.3-metre-span cantilever beam. The rig was made of channel sections pre-drilled with 22 mm holes for bolting purposes. Loading frames were formed through the use of sections fastened and bolted together and eventually anchored to the strong floor of the laboratory (Figure 13). For the purpose of representing the height of a residential building, the column height was considered as 3 metres. Both ends of the column were restrained from rotation. The lateral movement of the beam was also restrained. A hydraulic jack applied the concentrated load at a distance of 1.3 m from the column face. In order to simulate the quasi static loading chosen for this research, a monotonically increasing ‘ramp’ was incorporated. Two inclinometers were used to conduct the rotational measurements at the beam to column connection zone. Moreover, in order for the vertical deflection of the specimen to be precise, linear variable differential transducers (LVDTs) were positioned at the tip of the beam. The loading of the specimen was performed using 5-KN increments until the occurrence of a substantial deflection in the beam. At this stage, the deflection increment controlled the loading sequence as a small load increment resulted in a significant increase in deflection. This process was continued until the specimen failed. The failure condition was taken into account once a sudden or substantially enormous decrease in the concentrated load was observed or an outstanding deformation had occurred.

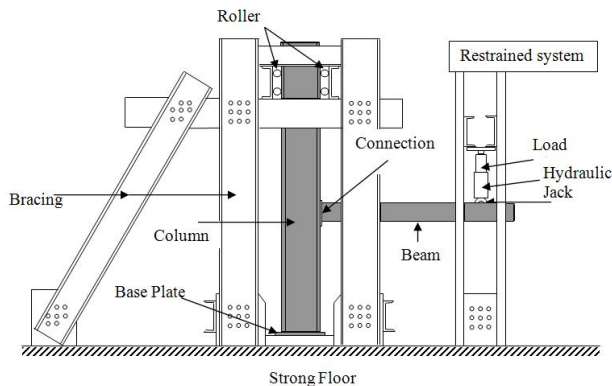

Figure 13: Test rig for full scale testing.

4.1 Description of Specimens

Six specimens were prepared to test the flush end-plate (FEP) representing semi-rigid or simple connections. This type of connection is not included in prequalified connections for special and intermediate steel moment frames for seismic applications (*Prequalified Connections for Special and Intermediate Steel Moment Frames for Seismic Applications (ANSI/AISC 358s2-14)* 2014). However, this type of connection is extensively used in existing steel structures in Malaysia because it is believed that it does not carry sufficient stiffness to develop the full capacity of a connected beam. Figure 14 highlights the typical geometrical configuration of the connection. Table 2 shows the size of beam, column, end plate, and the diameter of bolts that were employed in this study. A structural

hot-rolled I-shaped steel section, known as Perwaja Steel Section (PSS), was used in this study, which is produced in conformity with the British Standards Institute BS EN 10113 specifications. The PSS sections are produced locally in Malaysia. The specimens are categorised as FEP 1 to FEP 6. The column sizes used in this study were HB200 x 200 x 56.2 designated as a light column and HB300 x 300 x 83.5 designated as a heavy column. This was done on purpose to study the influence of changing the column size on failure mode of the connection. The beam size ranged from 250 mm to 500 mm deep. It is to be noted that the moment resistance of the connection changes substantially with an increase of the lever arm, which is a function of the beam depth. The thickness of the end-plate and bolts size is associated with the probable maximum moment of the connected beam at the plastic hinge location. An end-plate yield line mechanism is considered to identify the end plate thickness in conformity with ANSI/AISC 358. However, in this study, the connection's properties were selected based on currently practiced structure details in Malaysia. Accordingly, M20 bolts with grade 8.8 were used together with a 12 mm thick end-plate, whereas M24 bolts with grade 8.8 were used with a 15 mm thick end-plate. The end-plate widths differed from 200 to 250 mm, and the number of tension rows ranged from one to two. Fillet weld with a thickness of 10 mm and 8 mm was employed for welding end-plates to flanges and web of column, respectively. A series of tensile tests were conducted on the web and flange of columns, beams and end-plates of the specimens. Results are highlighted in Table 3, where f_y is yield strength, f_u is ultimate strength and E is modulus of elasticity.

Test No.	Column Sections	Beam Sections	Size of Bolt (in mm)	No. of Bolt Row in Tension	Size of End-plate		
					Width	Thickness	Depth
(in mm)							
FEP 1	HB 200 x 200 x 56.2 Flange = 12 mm thick Web = 12 mm thick	HB 250 x 125 x 25.1 Flange = 8 mm thick Web = 5 mm thick	M20	1	200	12	300
FEP 2	HB 200 x 200 x 56.2 Flange = 12 mm thick Web = 12 mm thick	HB 250 x 125 x 25.1 Flange = 8 mm thick Web = 5 mm thick	M24	1	200	15	300
FEP 3	HB 250 x 250 x 63.8 Flange = 11 mm thick Web = 11 mm thick	HB 400 x 200 x 65.4 Flange = 13 mm thick Web = 8 mm thick	M20	2	200	12	500
FEP 4	HB 250 x 250 x 63.8 Flange = 11 mm thick Web = 11 mm thick	HB 400 x 200 x 65.4 Flange = 13 mm thick Web = 8 mm thick	M20	2	250	12	500
FEP 5	HB 300 x 300 x 83.5 Flange = 12 mm thick Web = 12 mm thick	HB 500 x 200 x 102 Flange = 19 mm thick Web = 11 mm thick	M24	2	200	15	600
FEP 6	HB 300 x 300 x 83.5 Flange = 12 mm thick Web = 12 mm thick	HB 500 x 200 x 102 Flange = 19 mm thick Web = 11 mm thick	M24	2	250	15	600

Table 2: Sections and FEP connections properties.

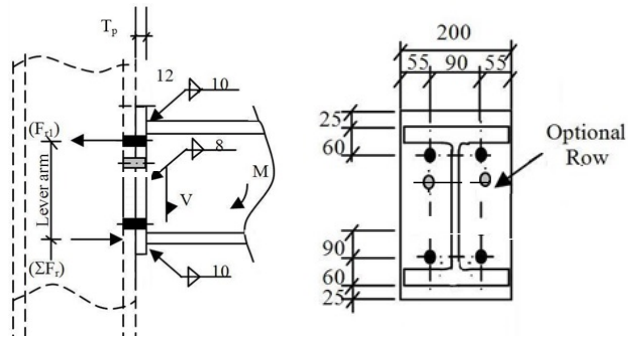

Figure 14: Flush end-plate connections as partial strength connections.

No.	Beams and Columns	Yield Strength, f_y (N/mm ²)	Ultimate Strength, f_u (N/mm ²)	Modulus of Elasticity, E (kN/mm ²)
1	200 x 200 x 56.2 (flange)	367	528	194
	200 x 200 x 56.2 (web)	385	547	198
2	250 x 250 x 63.8 (flange)	351	510	193
	250 x 250 x 63.8 (web)	351	540	192
3	300 x 300 x 83.5 (flange)	370	516	202
	300 x 300 x 83.5 (web)	359	510	194
4	250 x 125 x 25.1 (flange)	388	521	208
	250 x 125 x 25.1 (web)	356	506	193
5	400 x 200 x 65.4 (flange)	335	405	201
	400 x 200 x 65.4 (web)	312	509	198
6	500 x 200 x 102 (flange)	299	471	193
	500 x 200 x 102 (web)	357	499	195
7	End-plate (12 mm)			
	P1	305	467	203
	P2	308	491	205
	P3	309	470	204
8	End-plate (15 mm)			
	P4	310	515	204
	P5	311	524	205
	P6	308	507	203
Average		338	502	199.20
St.D		30.2	33	5.30

Table 3: Material's characteristic of end-plates, beams and columns.

5 RESULTS AND DISCUSSION

The most significant characteristic that describes the overall behaviour of the model is the moment-rotation curve. The complete moment-rotation curves for all six beam-to-column connections are shown in Figure 15.

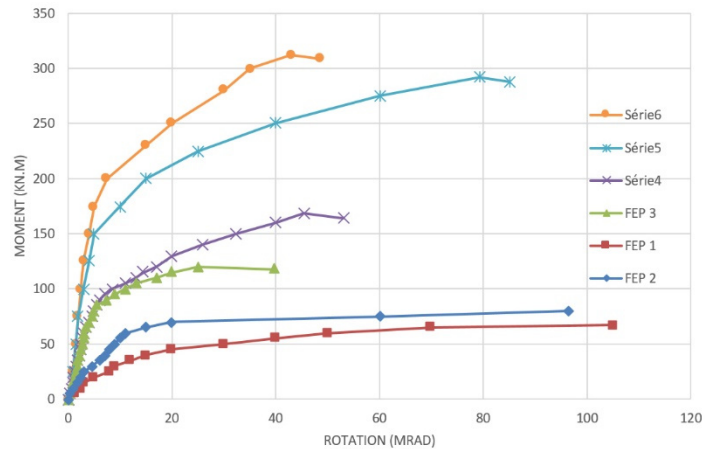

Figure 15: Moment-rotation curves of all six connections between beam and column.

In all the tests, specimens showed that the connections behaved linearly in the first stage followed by non-linear behaviour and gradually losing the stiffness with the increase in rotation. This is recognised, mainly, due to the concentrated deformation appearing at the tension region of the connections through the top bolt rows. The test mainly stopped due to a large deformation as the applied load started to decrease. Three different failure modes were identified as: i.) deformation of the end-plate, ii.) deformation of the column flange, and iii.) crushing of the column web. These typical failure modes are shown in Figures. 16-18. During the tests, no vertical slip was observed between end-plate and column. This was primarily due to the fact that the tightness of the bolts was considered during installation.



Figure 16: Failure mode of column flange and end-plate (FEP 2 connection).

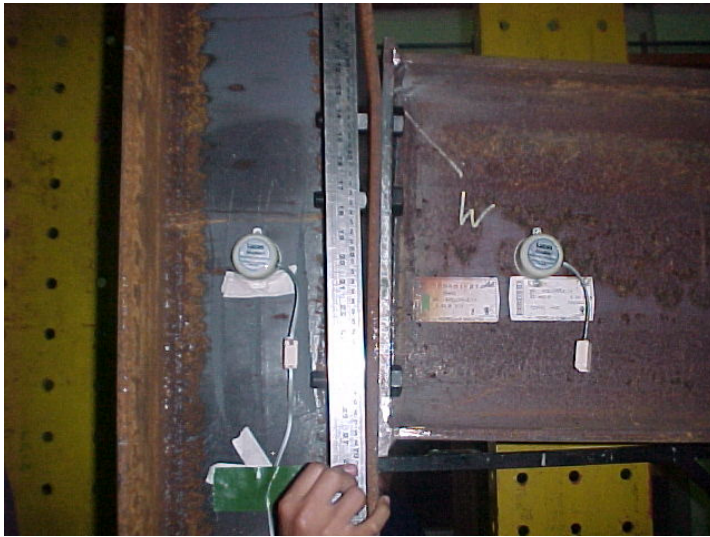

Figure 17: Failure mode of the column flange (FEP 3 connection).

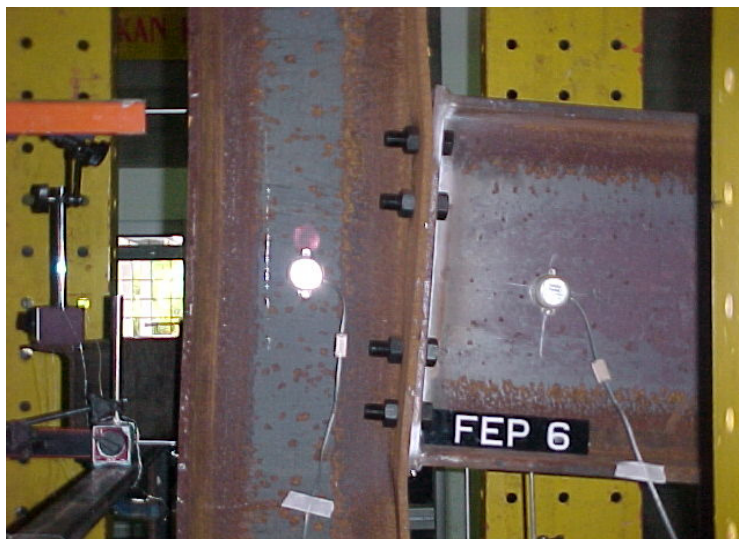

Figure 18: Crushing of column web in tension and compression zones (FEP 6 connection).

From $M-\theta$ Graphs, the behavioural characteristics of a particular joint can be determined based on the three significant parameters, which are the moment resistance (strength), the rotational stiffness (rigidity) and the rotational capacity (ductility). The rotation stiffness of the connection depends on the geometrical configuration of the connection. Generally, the higher the moment resistance of the connection, the stiffer the connections' stiffness. However, factor such as number of bolts, thickness of the plate, and depth of the beam play an important role to determine the stiffness of the connection. Therefore, it is best to present the rotation stiffness of the connection by comparing the moment resistance and relate to other connections' parameters. The results of the moment resistance, initial stiffness, and maximum rotation at maximum load are tabulated in Table 4.

Specimen	Moment of inertia of beam (cm^4)	Size and no. of bolt row (in mm)	End-plate thickness (mm)	Moment Resistance, M_i (kNm)	Rotation, θ_i (mRad)	Initial Stiffness, $S_{i,ini} = M_i / \theta_i$ (kNm/mRad)	Max. rotation at max. load., θ_u (mRad)
FEP 1	3450	20 (1 bolt row)	12 (W = 200)	35.1	11.3	3.1	104.9
FEP 2	3450	24 (1 bolt row)	15 (W = 200)	70.3	12.4	5.6	96.5
FEP 3	23457	20 (2 bolt rows)	12 (W = 200)	81.5	6.8	12	39.8
FEP 4	23457	20 (2 bolt rows)	12 (W = 250)	95	6	15.8	45.4
FEP 5	55481	24 (2 bolt rows)	15 (W = 200)	200	6	33	79.2
FEP 6	55481	24 (2 bolt rows)	15 (W = 250)	192	5.2	36.9	42.90

Table 4: Test results based on the moment versus rotation curves.

The bilinear concept was considered to calculate the initial stiffness from moment-rotation curve. In this method the intercept constant moment, M_i , is selected as the moment corresponding to the intersection of the moment axis and the strain hardening tangent stiffness line, which passes through the ultimate point, as shown in Figure 19. Therefore, the intercept constant moment is highly dependent on the connection ultimate moment (Massimo Latour *et al.* 2013).

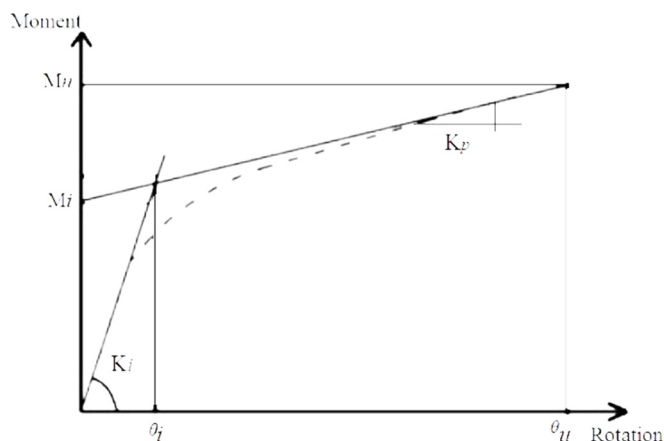

Figure 19: Description of initial stiffness (Massimo Latour *et al.* 2013).

The results of Table 4 generally show that the higher the moment resistance, the higher the initial stiffness of the connection. These results also show that the deeper the beam, the higher the initial

stiffness of the connection. This was because the use of deep beam had resulted in longer distance between tension zone and compression zone which reduced the rotation capacity of the connection. The thickness of the end-plate and the size of bolts also affects the stiffness of the connection. For 12mm thick end-plate in conjunction with M20 bolts, the stiffness of the connection was lesser than the 15mm thick end-plate in conjunction with M24 bolt. This issue could be seen by comparing specimen FEP 1 with specimen FEP 2 where the moment resistance and initial stiffness increased by 200% and 180% respectively. The effect of increasing the width of the end-plate from 200mm to 250mm could be seen by comparing specimen FEP 3 with FEP 4, and FEP 6 with FEP 7. In overall, the results show that the increase in the width of the end-plate with the same thickness did not result to a significant increase in both the moment resistance and the initial stiffness of the connection.

5.1 ANSI/AISC 360-10 Classification Overview

The fundamental criteria for AISC connection classification are established using the moment-rotation ($M-\theta$) curve where stiffness, strength and ductility are considered directly from the plotted graphs. Table 5 shows the calculated amounts of $\frac{k_s L}{EI}$ for all six connections which indicate that they should be treated as simple connections because the AISC specification contemplates the amount of 2 as the boundary limitation for simple connections. However, as shown in section 2, the analytical calculation resulted in the value of 0.5 for the boundary limitation of simple connection. Based on analytical boundary limitations for simple to semi-rigid connections of 0.5, the two specimens, namely FEP 1 and FEP 2, are categorised as semi-rigid connections and the rest of the specimens, FEP 3 to FEP 6, as simple connections.

Specimens FEP 3 to FEP 6 employed deep beams connected to columns. Their flexural strengths were two times higher than the columns. Table 5 shows that the flush end-plate failed to develop full capacity of connected beams, especially in FEP 3 to FEP 6 specimens, where the ratio of the maximum moment resisted by connection, M_n , to the plastic moment of the beam, $M_{p,beam}$, was around 0.35. Although this type of connection is classified as a simple or semi-rigid connection (based on AISC and analytical procedure), the failure modes of the experimental test showed that extensive deformations appeared in the column flange and shear panel zone within the tension region. Accordingly, the effects of joint flexibility should be addressed in the analysis of structures and consequently, the internal forces and bending moment diagrams constructed under the assumption of rigid joints contain considerable errors.

In accordance with AISC classification, connections that transfer less than 20 percent of the plastic moment of the connected beam at rotations of 0.02 radians should be treated as simple connections. Table 5 shows that all six beam to column connections transmitted more than 20 percent of the plastic moment of the connected beam at rotations of 0.02 radians. Accordingly, all six flush end-plate connections are not categorised as simple connections based on their strength. Nevertheless, as already mentioned, this type of connection could not develop adequate moment capacity of the connected beam. Table 5 also indicates that all specimens experienced rotation levels beyond 0.03 radians, which is equal to the minimum connection capacity as defined in the AISC for special moment frames. However, since the beam strength exceeds the connection strength, the deformation is only concentrated within the connection.

Specimen	M_s ($kN.m$)	M_n ($kN.m$)	$M_{0.02 \text{ Rad}}$ ($kN.m$)	ϑ_s ($radian$)	ϑ_u ($radian$)	$M_{p, \text{ Beam}}$ ($kN.m$)	$\frac{K_s}{\left(\frac{kN.mm}{radian} \times 10^6\right)}$	$\frac{k_s L}{EI}$
FEP 1	40	67.1	45	0.015	0.1	107.3	2.66	0.51
FEP 2	65	80.3	70	0.015	0.095	107.3	4.33	0.81
FEP 3	90	121.8	115	0.0075	0.04	452.1	12.00	0.34
FEP 4	95	168.5	130	0.007	0.045	452.1	13.57	0.37
FEP 5	150	292.2	220	0.005	0.08	860	30.0	0.32
FEP 6	200	312.3	250	0.0075	0.043	860	26.67	0.31

Table 5: Connection assessment based on AISI classification.

5.2 Eurocode 3 Part 1-8 Classification Overview

Eurocode classification requires the designer to identify the initial rotational stiffness ($S_{j,ini}$) as described in section 3-2, where $S_{j,ini}$ consists of flexibilities of its basic components (K_i). $S_{j,ini}$ should be compared with the connected beam capacity introduced as $\frac{EI_b}{L_b}$.

Table 6 shows basic component flexibilities (K_i), initial rotational stiffness ($S_{j,ini}$) and connected beam stiffness for all six specimens. The results indicated that connections FEP 1 and FEP 2 are categorised as semi-rigid while the rest of the specimens are categorised as simple ones. The results also emphasised that the Eurocode analysis method adequately predicted the initial rotational stiffness ($S_{j,ini}$) of connections compared to the equivalent value resulted from experimental test provided in Table 4. The thickness of the column flange and end-plate has been defined, respectively, by K4 and K5 that had a great impact on initial rotational stiffness ($S_{j,ini}$) of connections. The deformation of the end-plate is frequently evaluated using a simple substitute model, the T-stub (Yoke Leong Yee & Robert E Melchers 1986; P Zoetemeijer 1974), which is assumed to represent the behaviour of the tension zone of the joint, as illustrated in Figure 20a. Moreover, the T-stub usually exhibits the following three failure modes, typically shown in Figure 20b:

- i. End-plate yielding without bolt failure (type 1).
- ii. Simultaneous yielding of end-plate with bolt failure (type 2).
- iii. Bolt failure without end-plate yielding (type 3).

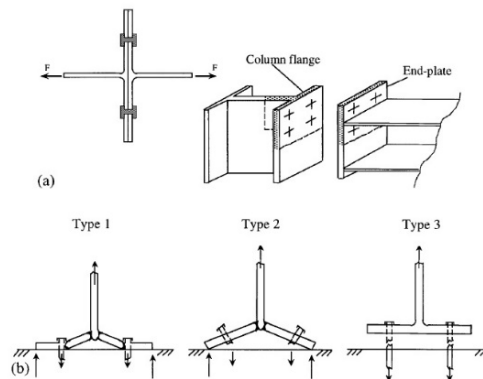

Figure 20: Equivalent T-stub assembly.

Experimental test data revealed that all six specimens experienced type 1 failure mode where yielding was mainly concentrated in the column flange and end-plate. Except for the column stiffened by the continuity plate, the column flange behaved similarly to the end-plate in bending, where the T-Stub approach is equally symmetrical.

Specimen	K1	K2	K3	K4	K5	K10	Keq	$\frac{EI_b}{L_b}$ $\left(\frac{kN \cdot mm}{radian} \times 10^6\right)$	$S_{j,ini}$ $\left(\frac{kN \cdot mm}{radian} \times 10^6\right)$
FEP 1	4.56	7.3	8.4	1	1	13.9		5.2	3.1
FEP 2	4.56	7.3	8.4	1	1.8	20		5.2	3.8
FEP 3	3.4	5.4					0.52	35.9	9.2
FEP 4	3.4	5.4					0.52	35.9	9.2
FEP 5	3.4	5.3					1.56	84.9	32.3
FEP 6	3.4	5.3					1.56	84.9	32.3

Table 6: Connection assessment based on Eurocode classification.

Eurocode classification categorises connections based on their moment resistance, where the connections that possess moment resistances smaller than 25% moment resistance of the connected beam are considered as simple connections. However, for connection with moment resistance, more than 25% but less than 100% moment resistance of the connected beam, the connection is classified as partial strength connection. The connection is classified as full strength connection if the connection strength is more than 100%. Accordingly, based on the data provided in Table 5, all six beams to column connections are categorised as semi-rigid connections as they transfer more than 25% of the connected beam plastic moment.

6 ANALYSES OF RESULTS

Eurocode and AISC classification adopt a simplified bilinear design moment–rotation curve. The characteristics of this approximate curve are plastic flexural resistance, initial stiffness and rotation capacity. The most important components that may significantly contribute to the rotation capacity of the end-plate connection is: column web in compression, column web in tension, column web in shear, column flange in bending and end-plate in bending (Figure 21). In the following sections the effects of some of these components on initial stiffness and ultimate moment capacity were investigated.

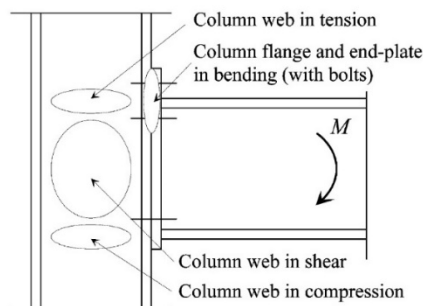

Figure 21: Basic end-plate components.

6.1 Column-Beam Moment Ratios

Column-beam moment ratios shall conform to the requirements of the AISC Seismic provisions as following:

$$\frac{\sum M_{pc}}{\sum M_{pb}} > 1 \quad (17)$$

where,

$\sum M_{pc}$ is the sum of the moments in the column above and below the joint at the intersection of the beam and column centerlines.

$\sum M_{pb}$ is the sum of the moments in the beams at the intersection of the beam and column centerlines.

Figure 22 shows the effect of column-beam moment ratio on the connection initial-beam stiffness ratio for the connection types shown in Table 2. Because the beam and column properties for FEP1-2, FEP3-4 and FEP5-6 are same the average value of initial stiffness was selected. It can be noticed from Figure 22 that increasing of column-beam moment ratio increases the initial stiffness. The failure mode in connections with high strong column-beam moment ratio controlled mainly by end-plate and column flange did not experienced severe buckling. The column flange in this system possess substantial resistance against flexural bending which seriously affect the initial stiffness of connection.

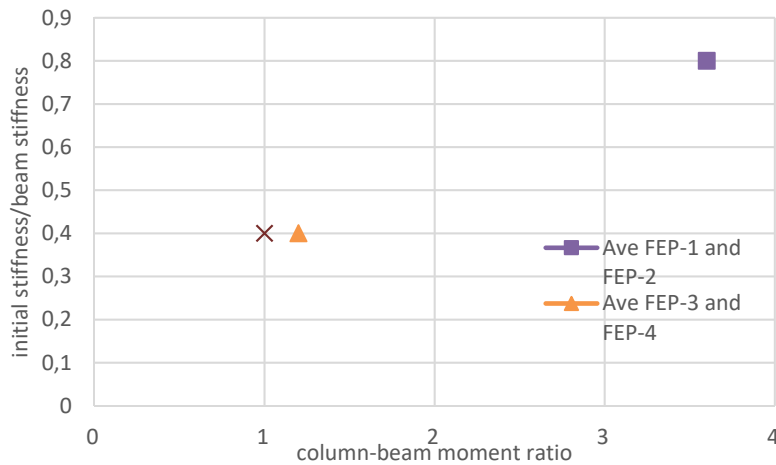

Figure 22: Effect of column-beam moment ratios on initial-beam stiffness.

6.2 Column Shear Panel Zone Capacity

The shear panel zone has shown an outstanding yielding mainly in the FEP 5 and 6 which is not a desirable condition. This issue affect the interstory drift angle and initial stiffness of connection. In order to overcome this flaw, the panel zone should be improved. There are two general solutions for this problem based on many guidelines:

- i. The desirable depth for column should be chosen;
- ii. The desirable thickness of the column web should be chosen.

According to AISC, the following equation should be considered in designing the panel zone [17]:

$$V_{pz} < V_y$$

where

V_{pz} is the design shear in column centerline and V_y is the ultimate shear capacity of panel zone. According to this code, V_y and V_{pz} can be calculated from the following equations [2]:

$$V_y = 0.6F_{yc}d_c t_{wc} \left\{ 1 + \frac{3b_c t_{cf}^2}{d_b d_c t_{wc}} \right\} \quad (18)$$

$$V_{pz} = 0.8 \frac{M_{pb}}{d_b} \quad (19)$$

which

M_{pb} and d_b are plastic moment and depth of beam, respectively. F_{yc} , d_c , t_{wc} , b_c , and t_{cf} are yield stress, depth, web thickness, flange width, and flange thickness of column, respectively.

Figure 23 shows the effect of V_{pz} / V_y ratio on the connection initial-beam stiffness ratio for the connection types shown in Table 2. Figure 23 indicated that by increasing the ratio of design shear in column centreline to ultimate shear capacity of panel zone, V_{pz} / V_y , the initial stiffness was decrease. Specimens with high ratio of V_{pz} / V_y experienced excessive plasticity in column shear panel zone as shown in Figure 18. This issue seriously affect the connection deformation and initial stiffness. Moreover, the contribution of panel zone deformation to the story drifts of steel moment frames is significant and should be taken into consideration using appropriate mathematical models i.e. the Scissors and Krawinkler models (JM Castro *et al.* 2005; H Krawinkler & S Mohasseb 1987).

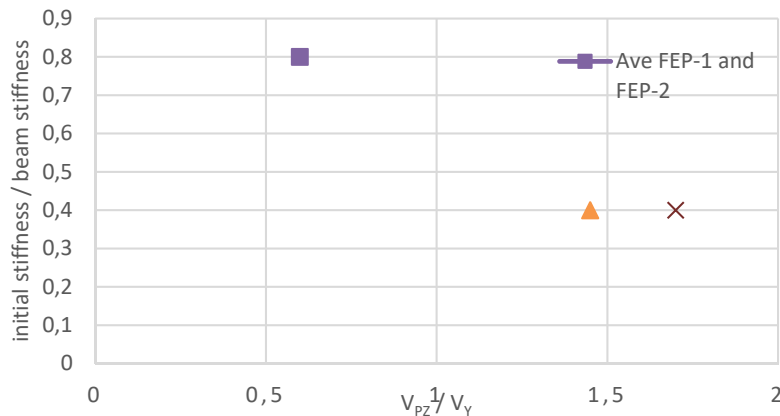

Figure 22: Effect of column shear panel zone on initial-beam stiffness.

7 SUMMARY AND CONCLUSIONS

This paper presents an overview of the classification of steel beam to column connections as prescribed by ANSI/AISC 360-10, and Eurocode 3 Part 1-8 in terms of stiffness, ultimate strength, and ductility requirements. The behaviour of beams with semi-rigid or partially restrained connections have also been discussed through the use of classical methods of analysis. Tests were carried out to investigate the moment-rotation features of flush end-plate (FEP) representing semi-rigid connections. Initial

stiffness and moment-rotation curves were measured for beam-to-column connections with variable geometry. Based on the analytical and experimental results of this study, the following conclusions are drawn:

- i. The prescribed value of 2 (by ANSI/AISC 360-10) was too conservative as the boundary limitation for simple connections to semi-rigid connections. However, a classical method analysis of beams with semi-rigid connections revealed that a value of 0.5 was more reliable for this purpose compared to the test results.
- ii. The experimental moment-rotation ($M-\theta$) curves showed that all six beams to columns connections experienced extensive rotations. Consequently, this flexible behaviour should be addressed in an analysis of the entire structure. There is a vital need to take into account that amplified beam-to-column connection plasticity can produce a considerable second-order ($P-\Delta$) effect in the whole structure that should be considered in the analysis.
- iii. The increase in the moment resistance and initial stiffness of the FEP connections was significantly improved as the size, the number of bolt and the depth of the beam increased. However, the increase in the thickness of the end-plate should also take into consideration.
- iv. Eurocode 3 Part 1-8 resulted in realistic predictions of beam to column classifications where the initial rotational stiffness ($S_{j,ini}$), extracted by basic component flexibilities (K_i), were in good agreement with the initial stiffness values derived from experimental tests.
- v. Both experimental test and analytical methods indicated that the thickness of column flange and end-plate significantly affect the initial rotational stiffness among other geometric parameters of flush end-plate beam to column connections.
- vi. The initial stiffness significantly increases with the increase of column-beam moment ratio capacity, while it decrease with the increase of design shear in column centreline to ultimate shear capacity of panel zone, V_{pz} / V_y , ratio.
- vii. The beam-to-column relationship should satisfy the requirements of AISC seismic provisions (*Seismic Provisions for Structural Steel Buildings* 2010) to address the requirement of initial stiffness. Furthermore, the design criteria should provide adequate strengths in the components of the beam-to-column connections to confirm that the plastic deformation is only accomplished by beam yielding rather than connection.

Acknowledgement

The authors wish to thank the esteemed technical staff of the Structures and Materials Laboratory, Universiti Teknologi Malaysia (UTM) for their cooperation and support in this study. Financial support provided by the Universiti Teknologi Malaysia Construction Research Centre (CRC) for conducting the experimental work was invaluable, and authors remain obliged.

References

- 1-8, E.-P. (2005). *Eurocode 3: Design of steel structures - Part 1-8: Design of joints*. EUROPEAN COMMITTEE FOR STANDARDIZATION.
- 360-10, A. A. (2010). *Specification for Structural Steel Buildings (ANSI/AISC 360-10)*. AISC Committee on Specifications.

- Azizinamini, A., & Radziminski, J. B. (1989). Static and cyclic performance of semirigid steel beam-to-column connections. *Journal of Structural Engineering*, 115(12), 2979-2999.
- Bayo, E., Cabrero, J., & Gil, B. (2006). An effective component-based method to model semi-rigid connections for the global analysis of steel and composite structures. *Engineering structures*, 28(1), 97-108.
- Bjorhovde, R., Colson, A., & Brozzetti, J. (1990). Classification system for beam-to-column connections. *Journal of Structural Engineering*, 116(11), 3059-3076.
- Brunesi, E., Nascimbene, R., & Rassati, G. (2014). Response of partially-restrained bolted beam-to-column connections under cyclic loads. *Journal of Constructional Steel Research*, 97, 24-38.
- Castro, J., Elghazouli, A., & Izzuddin, B. (2005). Modelling of the panel zone in steel and composite moment frames. *Engineering structures*, 27(1), 129-144.
- Chen, W.-F., & Kishi, N. (1989). Semirigid steel beam-to-column connections: Data base and modeling. *Journal of Structural Engineering*, 115(1), 105-119.
- Coelho, A. M. G., & Bijlaard, F. S. (2007). Experimental behaviour of high strength steel end-plate connections. *Journal of Constructional Steel Research*, 63(9), 1228-1240.
- Díaz, C., Victoria, M., Querin, O. M., & Martí, P. (2012). Optimum design of semi-rigid connections using metamodels. *Journal of Constructional Steel Research*, 78, 97-106.
- Hsieh, S.-H., & Deierlein, G. (1991). Nonlinear analysis of three-dimensional steel frames with semi-rigid connections. *Computers & structures*, 41(5), 995-1009.
- Jones, S., Kirby, P., & Nethercort, D. (1983). The analysis of frames with semi-rigid connections—a state-of-the-art report. *Journal of Constructional Steel Research*, 3(2), 2-13.
- Jones, S., Kirby, P., & Nethercot, D. (1980). Effect of semi-rigid connections on steel column strength. *Journal of Constructional Steel Research*, 1(1), 38-46.
- Kartal, M., Basaga, H., Bayraktar, A., & Muvafik, M. (2010). Effects of semi-rigid connection on structural responses. *Electronic journal of structural Engineering*, 10(10), 22-35.
- Kishi, N., Hasan, R., Chen, W., & Goto, Y. (1997). Study of Eurocode 3 steel connection classification. *Engineering structures*, 19(9), 772-779.
- Krawinkler, H., & Mohasseb, S. (1987). Effects of panel zone deformations on seismic response. *Journal of Constructional Steel Research*, 8, 233-250.
- Latour, M., Piluso, V., & Rizzano, G. (2013). Experimental behaviour of friction T-stub beam-to-column joints under cyclic loads. *Steel Construction*, 6(1), 11-18.
- Lee, S.-S., & Moon, T.-S. (2002). Moment-rotation model of semi-rigid connections with angles. *Engineering structures*, 24(2), 227-237.
- Nethercot, D., Li, T., & Ahmed, B. (1998). Unified classification system for beam-to-column connections. *Journal of Constructional Steel Research*, 45(1), 39-65.
- Nguyen, P.-C., & Kim, S.-E. (2014). An advanced analysis method for three-dimensional steel frames with semi-rigid connections. *Finite Elements in Analysis and Design*, 80, 23-32.
- Prequalified Connections for Special and Intermediate Steel Moment Frames for Seismic Applications (ANSI/AISC 358s2-14). (2014). An American National Standard.
- Seismic Provisions for Structural Steel Buildings (2010). AISC committee on Specifications.
- Simoes, L. (1996). Optimization of frames with semi-rigid connections. *Computers & structures*, 60(4), 531-539.
- Yee, Y. L., & Melchers, R. E. (1986). Moment-rotation curves for bolted connections. *Journal of Structural Engineering*, 112(3), 615-635.
- Zoetemeijer, P. (1974). A design method for the tension side of statically loaded, bolted beam-to-column connections. *HERON*, 20 (1), 1974.