

One-Way Shear Resistance of RC Members with Unconnected Stirrups

Abstract

This paper presents results of eight experimental tests carried to evaluate the mechanical performance of unconnected “W” stirrups. Reinforced concrete wide beams were tested and their characteristics were idealized to represent column strips in flat slab buildings. The main variables were: the type of shear reinforcement; the shear span to effective depth ratio (a_v/d); and the flexural (ρ_l) and shear (ρ_w) reinforcement ratios. In general, both the response and the shear resistance of the structural elements with unconnected “W” stirrups was similar to those elements with vertical closed stirrups. Increments of shear resistance of up to 84% were achieved, indicating that they have high potential for use as shear reinforcement in slab-column connections.

Keywords

Reinforced concrete; Shear resistance; Shear reinforcement.

Maurício P. Ferreira ^{a, *}

Rafael N. M. Barros ^a

Manoel J. M. Pereira Filho ^a

Luamim S. Tapajós ^a

Felipe S. Quaresma ^a

^a Faculty of Civil Engineering, Institute of Technology, Federal University of Para, Belem, Para, Brazil.

Corresponding author:

* mpina@ufpa.br

<http://dx.doi.org/10.1590/1679-78252872>

Received 20.02.2016

In revised form 22.09.2016

Accepted 29.09.2016

Available online 04.10.2016

1 INTRODUCTION

In reinforced concrete buildings, the use of flat slabs (see Figure 1a) or ribbed slabs supported on wide beams (see Figure 1b) is common if a flat flooring system is desired. Both cases are susceptible to abrupt shear failures, which can occur with low levels of cracking and displacement, as shown in Figures 1c and 1d. The use of shear reinforcement improves both ductility and ultimate resistance, but their structural performance is significantly dependent of its anchorage at their ends. In such situations, in order to improve the force transfer mechanisms, design standards recommend that the shear reinforcement such as stirrups shall extend as close as possible to the compression and tension

surfaces. They also recommend that between anchored ends, each bend shall enclose a longitudinal bar. However, for flat slabs this can significantly complicate the construction process, especially if a radial arrangement distribution of the shear reinforcement is desired, as it favours clashes with the flexural rebars.

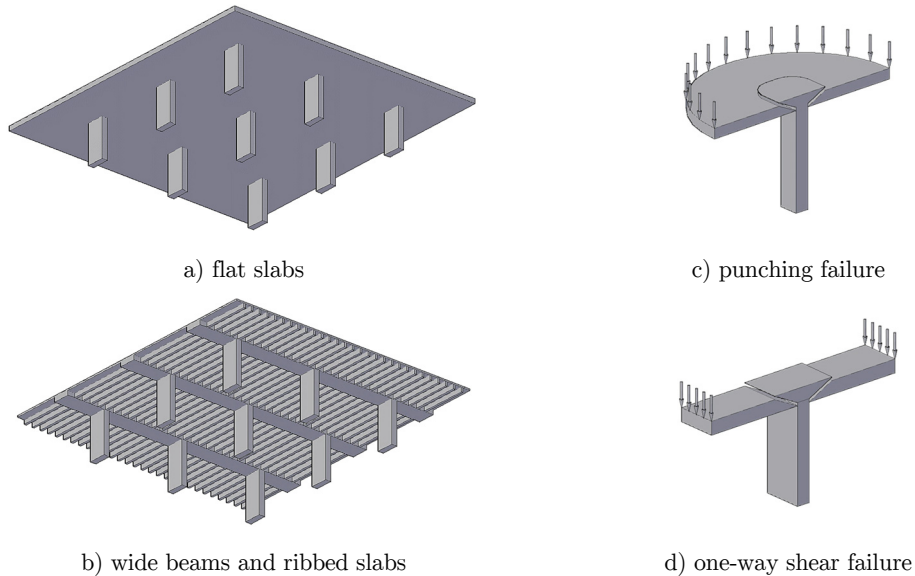

Figure 1: Shear failure of flat flooring systems

The use of shear reinforcement internally anchored on flexural rebars could solve this construction issue, but in terms of research is a subject where little experimental evidence is available. The main results were provided by Yamada et al. (1992), Gomes and Andrade (2000), Regan and Samadian (2001), Pilakoutas and Li (2003), Park et al. (2007), Trautwein et al. (2011) Furche (1997) Caldentey et al. (2013) and Furche and Bauermeister (2014) and involve tests on slab-column connections. Results show that in such cases, loss of anchorage can lead to premature failures due to delamination. The use of transverse welded bars or complementary reinforcement are alternatives to improve the anchorage conditions and avoid premature failures.

This paper presents results of eight tests on reinforced concrete wide beams where a new kind of internal shear reinforcement was tested. Named as “W” stirrups, this reinforcement consists of pre-fabricated cages made with continuous lattice girders joined in different layers by transverse bars welded at their vertices as show in Figure 2. They were developed to be used as shear reinforcement in slab-column connections and Figure 3 illustrate some constructive arrangements. In Figures 3a and 3b, plain views from slab-column connections with cruciform and grid distributions of the unconnected “W” stirrups are shown. Figures 3c and 3d present detailed cross sections of the slab-column connections. The characteristics of the tested wide beams were defined in order to simulate the column strips in flat slab buildings. Their flexural and shear response are presented and the ultimate loads are compared to those theoretically predicted by ACI 318 (2014), Eurocode 2 (2004) and the Brazilian Code ABNT NBR 6118 (2014).

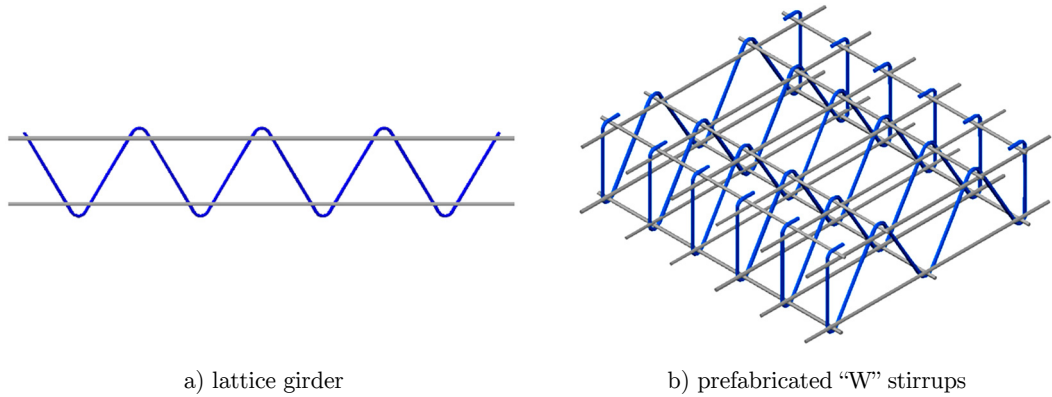

Figure 2: Prefabricated cage of “W” stirrups.

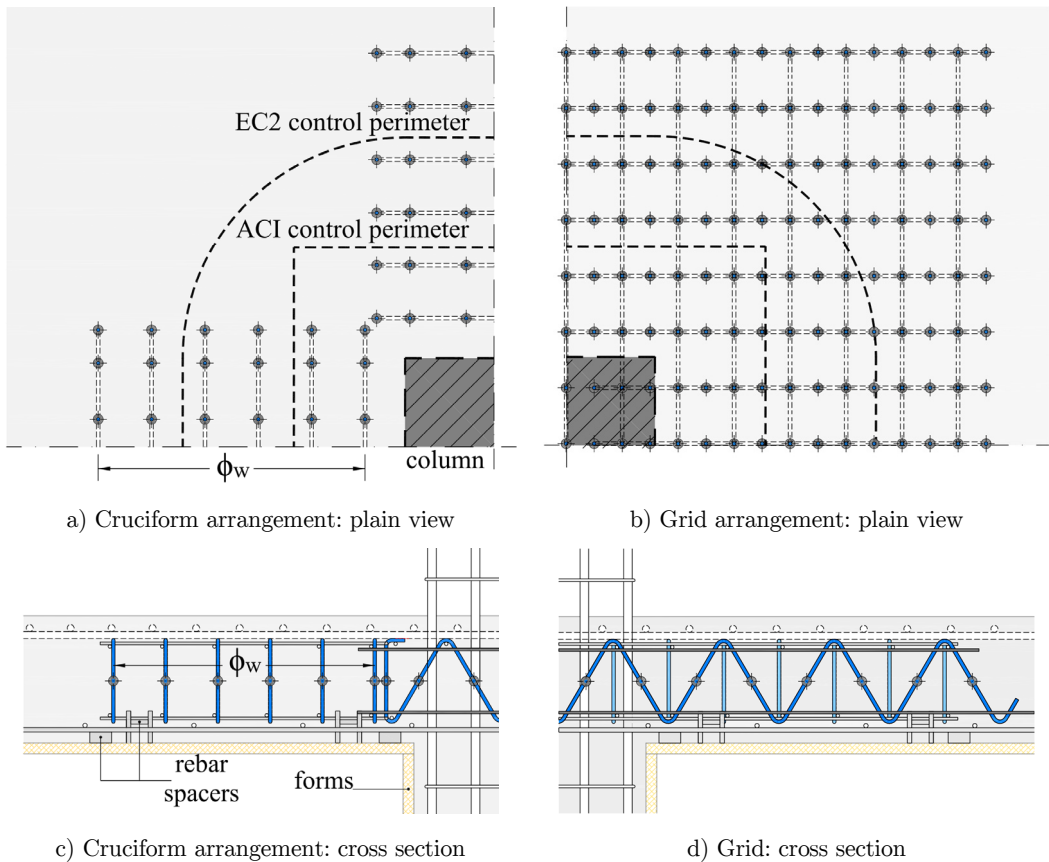

Figure 3: Arrangements of “W” stirrups in slab-column connections.

2 THEORETICAL BACKGROUND

2.1 Shear Reinforcement for Flat Slabs

For flat slabs, the effectiveness of a shear reinforcement is directly dependent of its capacity of absorb tensile forces and properly transfer them to concrete. Furthermore, they need to be practical for both manufacture and installation. These requirements are not easily achieved in practice, once that flat slabs are slender structural elements. Therefore, a wide variety of types of shear reinforcement has been tested and this paper summarizes some of the most important contributions in this area.

The first type of shear reinforcement proposed for flat slabs consisted of bent-up bars as shown in Figure 4a (e.g. see Graf, 1938, Elstener and Hoognestad, 1956, and Anderson, 1963), which can be highly efficient and economical when combined with other types of reinforcement, such as stirrups as shown by Broms (2000).

Various types of stirrups were also tested for flat slabs. The most common types are closed stirrups (Figure 4b) and open stirrups (Figure 4c), but there are others like continuous stirrups (Figure 4d), which were first tested by Seible et al. (1980), and inclined stirrups (Figure 4e). In general, closed and continuous stirrups are not commonly used in practice because it impairs the installations of rebars. On the other hand, although open stirrups provide more versatility to both design and construction, they tend to raise costs because they are laborious in terms of production and installation. Research conducted in Brazil by Melo et al. (2000), Andrade (2000) and Trautwein (2001) present results of tests on stirrups with inclination of 45° and 60° in relation to the slab plane. The latter showed excellent structural performance, but their use is restricted once they are not practical.

Chana (1993) developed preassembles of shear reinforcement (Figure 4f) which consisted of individual "u" shaped stirrups joined by welded deformed bars. The aim was to present a prefabricated cage capable of minimizing the *in situ* activities, reducing the labour costs. Beutel and Hegger (2000) introduced stirrups with high mechanical and constructive performance. In the first type of stirrups, shown in Figure 4g, only the upper bending rebars are enclosed by the stirrups, while in the second type (Figure 4h), both the upper and lower flexural rebars are embraced. In both cases, the structural performance observed in tests was adequate.

Stud rails (Figure 4i) and double-headed studs (Figure 4j) are industrialized types of shear reinforcement with high control in both manufacturing and assemblage. The mechanical anchorage provided by their heads results in excellent structural performance, as introduced by Dilger and Ghali (1981) and more recently reported by Ferreira et al. (2014). The shear reinforcement used by Gomes and Regan (1999) was made of I-beam cut-off sections embraced in the flexural reinforcement, like show in Figure 4k and were initially tested by Langohr et al. (1976). They were effective to prevent punching shear failures, more than doubling the load capacity observed for the reference slab without shear reinforcement.

All types of shear reinforcement described above generate clashes with the flexural rebars, especially when radial arrangements are used. Regan and Samadian (2001) present results from two tests carried in 1993 in slabs with a new kind of shear reinforcement called Riss Star (Figure 4l). They were introduced by Alpenländische Veredelungs Industrie and subsequently marketed in Switzerland by Riss. They are practical to use as they do not enclose the bending reinforcement and serve as support for the upper flexural rebars. Results showed that they have adequate structural performance,

since increments of resistance up to 70% were observed. Gomes and Andrade (2000) and Trautwein et al. (2011) tried to improve this idea and developed internal stud rails in which “u” shaped hooks were used to improve anchorage (see Figure 4m). Their results showed that the shear reinforcement was effective and that the hooks used were able to control the horizontal cracks between the shear reinforcement and the lower flexural rebars.

Figure 4n presents a recent type of punching shear reinforcement. Produced by Filigran Träger-systeme GmbH & Co and commercialized in Europe by Halfen, they were first tested by Furche (1997) and consist of prefabricated lattice girders made with three rebars chords connected by welded diagonals. One of the diagonal is intentionally vertical and the other has an inclination of 45° . They are used in in situ and precast concrete solutions to prevent punching shear and to provide support for the upper flexural reinforcement. The European Organization for Technical Assessment (EOTA) published the European Technical Assessment ETA 13/0521 (2013) that provides guidelines for the design of flat slabs with this new kind of shear reinforcement.

The positioning of the shear reinforcement is essential for their structural performance and design standards make recommendations in this regard. In case of flat slabs, they define limit values for both the position of the first reinforcement perimeter (s_0) and for the spacing between radial perimeter (s_r). These rules try to guarantee that the reinforcement is able to control the opening of shear cracks. This directly affects the shear resistance of concrete elements for two main reasons: the opening of shear cracks tend to reduce concrete resistant mechanisms like aggregate interlock; and the spacing is going to determinate the number of bars effectively intercepted by the failure surface. Figure 5a illustrates the punching shear failure of a slab-column connection. It is possible to notice that the spacing rules seek to prevent that the shear reinforcements is placed in low anchorage areas.

Flat slabs are slender elements where the anchoring conditions of shear reinforcement are unfavourable. According to Regan (2000), for a straight crack, the critical embedded length is only $1/4$ of the effective height of the shear reinforcement. In practice, this often limits the average stress in the shear reinforcement to levels below the yield stress. Furthermore, the anchoring conditions may be different depending on the cracking degree of concrete in which the reinforcement is anchored. In Figure 5a, the lower zone is usually uncracked while in the upper area the concrete may be cracked. Cracking of concrete reduces the pull-out resistance of a rebar as reported by Eligehausen and Balogh (1995).

Regan (2000) assessed through pull-out tests the influence of the anchoring system in the response and resistance of steel anchors embedded in uncracked concrete with small embedment depths (less than 100 mm). Figure 5b summarize the experimental results. The inclination of the failure surface does not seem to affect significantly the pull-out resistance. The author also observed that 90° hooks embracing transversal reinforcement seem to be the most efficient anchorage situation.

Beutel and Hegger (2002) conducted a similar analysis. They used nonlinear computational models to evaluate the performance of tensile bars embedded in uncracked concrete varying the type of anchorage. Figure 6 shows the stress-slip response and it is possible to observe that although the yield stress was reached for cases F, G and H, the anchorage slip is affected by the anchorage detailing.

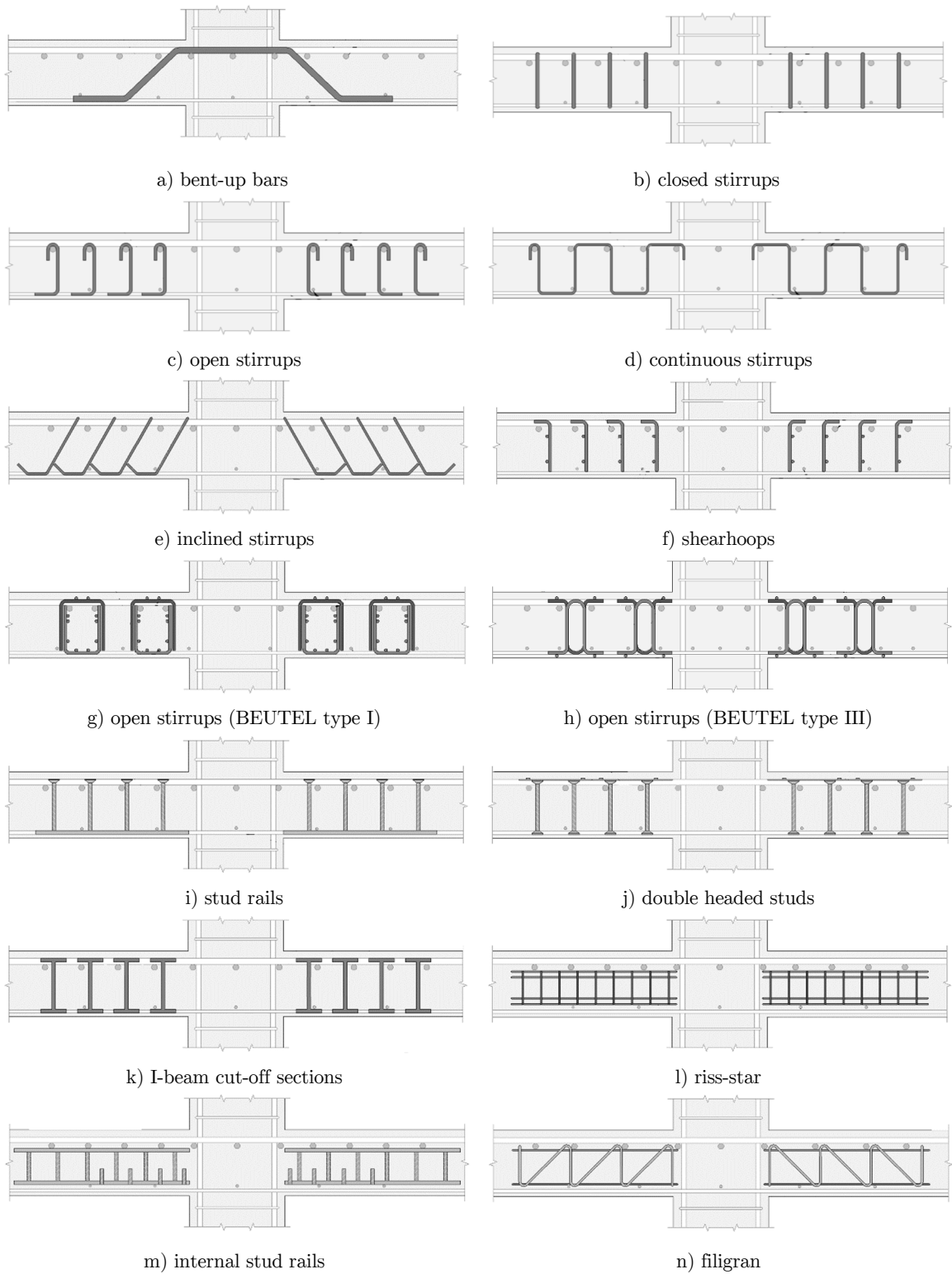

Figure 4: Types of shear reinforcement for flat slabs.

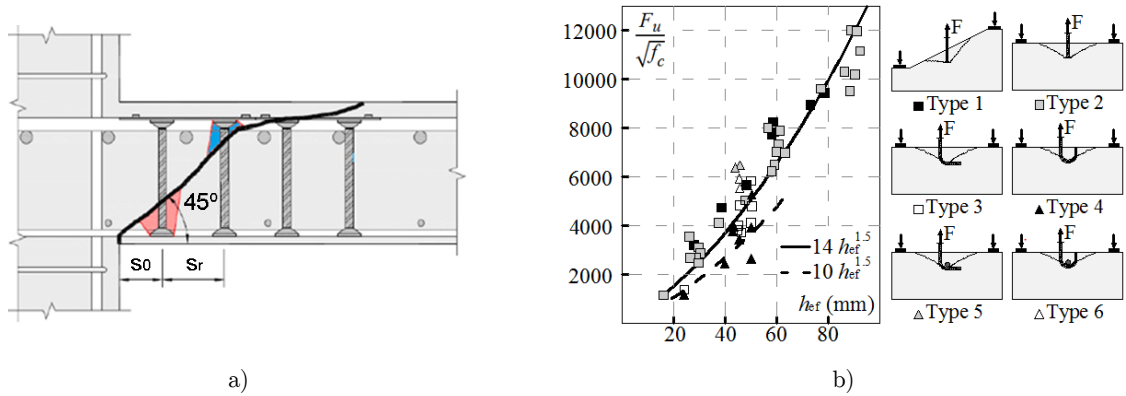

Figure 5: a) Different anchorage conditions in a slab-column connection.
 b) Pull out resistance of tensioned bars (Regan, 2000).

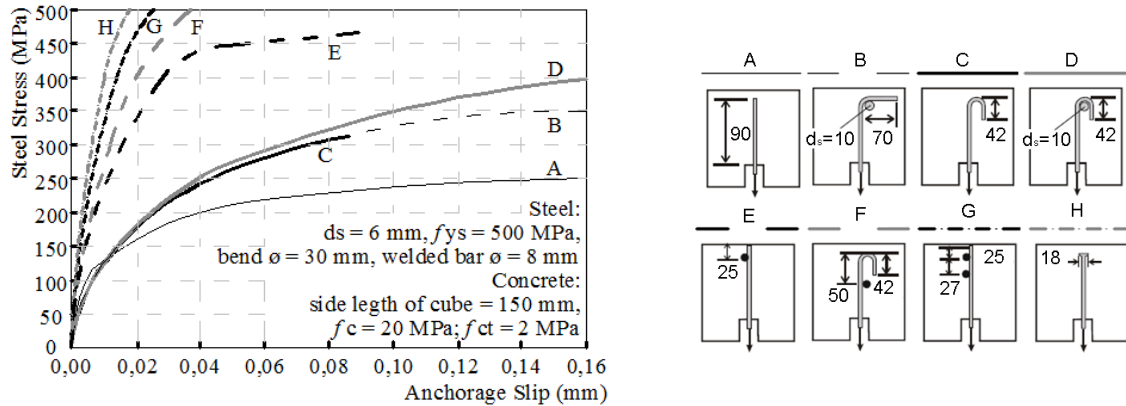

Figure 6: Computational analysis of different anchorage types (Beutel and Hegger, 2002).

2.2 Methods of Calculation

This item summarizes the recommendations presented by Eurocode 2 (2004), ACI 318 (2014) and ABNT NBR 6118 (2014) to determine the one-way shear strength of reinforced concrete elements. They are based on truss analogies and different assumptions are taken to determinate the inclination of the concrete struts and to calculate the contributions from concrete and from the shear reinforcement. The equations presented in this paper are limited to the cases of reinforced concrete elements under transverse loads: without axial forces; with rectangular cross section; with constant cross section along the shear span; with shear span $\geq 2d$; with concrete made with conventional aggregates and with compressive strength up to 50 MPa. In the end of this section it is presented the calculation process to determinate the flexural capacity of the tested beams, based on the recommendations presented by ABNT NBR 6118 (2014), which respects the equilibrium of forces and moments in the cross-section.

Eurocode 2 (2004)

Eurocode 2 recommends Equation 1 to calculate the shear strength of elements without transverse reinforcement. This equation considers, semi-rationally, the reduction of the shear capacity due to size effect (factor k) and the favourable influence of the tension flexural reinforcement (dowel effect) through term ρ_l .

$$V_{R,c} = \max \left\{ \begin{array}{l} \left(0.18 \cdot k \cdot (100 \cdot \rho_l \cdot f_c)^{1/3} \right) \cdot b_w \cdot d \\ 0.035 \cdot k^{3/2} \cdot \sqrt{f_c} \cdot b_w \cdot d \end{array} \right. \quad (1)$$

Where:

f_c is the concrete compressive strength;

b_w is the width of the cross section and d is the effective depth of the element.

$$k = 1 + \sqrt{\frac{200}{d}} \leq 2.0;$$

$$\rho_l = \frac{A_{st}}{b_w \cdot d} \leq 2.0.$$

For elements with transverse reinforcement, Eurocode 2 considers variable strut inclination method, which assumes that the shear force is resisted by a truss model where concrete struts are equilibrated by the shear reinforcement ignoring the tensile contribution of concrete. In this case, the angle between the longitudinal axis of the beam and the concrete strut is allowed to vary between 21.8° and 45° , depending upon the applied shear force. The shear resistance in such cases is expressed in Equation 2, not higher than the maximum shear resistance defined by Equation 3.

$$V_{R,cs} = \max \left\{ \begin{array}{l} \frac{A_{sw}}{s} \cdot 0.9 \cdot d \cdot f_{yw} \cdot (\cot \theta + \cot \alpha) \cdot \sin \alpha \\ V_{R,c} \end{array} \right. \quad (2)$$

Where:

A_{sw} is the area of shear reinforcement;

s is the spacing of the stirrups;

d is the effective depth of the member;

f_{yw} is the yield stress of the shear reinforcement;

θ is the angle of the concrete strut, $1 \leq \cot \theta \leq 2,5$;

α is the angle between the shear reinforcement bars and the longitudinal axis of the beam.

$$V_{R,max} = \frac{0.9 \cdot b_w \cdot d \cdot \nu_1 \cdot f_c \cdot (\cot \theta + \cot \alpha)}{1 + \cot^2 \theta} \quad (3)$$

Where:

ν_1 is a strength reduction factor for concrete with skew cracks, calculated with Equation 4.

$$\nu_1 = 0.6 \cdot \left[1 - \frac{f_c}{250} \right] \quad (4)$$

ABNT NBR 6118 (2014)

The Brazilian standard specifies two different models to calculate the shear resistance of reinforced concrete elements. In both cases, it assumes that the shear strength $V_{R,cs}$ is the result of the sum of the contributions from concrete ($V_{R,c}$) and from the shear reinforcement ($V_{R,s}$) as shown in Equations 5 and 9. Model I states that the shear strength $V_{R,cs I}$ shall be calculated assuming a fixed angle of the concrete strut of $\vartheta = 45^\circ$ and thus the concrete and steel contributions can be calculated with Equations 6 and 7, respectively. The maximum shear strength is given by Equation 8.

$$V_{R,cs I} = V_{R,c I} + V_{R,s I} \quad (5)$$

$$V_{R,c I} = V_{c0} = 0.6 \cdot f_{ctk,inf} \cdot b_w \cdot d \quad (6)$$

$$V_{R,s I} = \left(\frac{A_{sw}}{s} \right) \cdot 0.9 \cdot d \cdot f_{yw} \cdot (\sin \alpha + \cos \alpha) \quad (7)$$

$$V_{R,max I} = 0.27 \cdot \left(1 - \frac{f_c}{250} \right) \cdot f_c \cdot b_w \cdot d \cdot (\cot \alpha + 1) \quad (8)$$

Where:

$f_{yw} = \min(f_{yw}; 500 \text{ MPa})$ is the yield stress of the stirrups;

$f_{ctk,inf} = 0.7 \cdot f_{ct,m}$ is the 5% fractile tensile strength of concrete;

$f_{ct,m}$ is the mean axial tensile strength of concrete defined for concretes with $f_c \leq 50 \text{ MPa}$ as

$$f_{ct,m} = 0.3 \cdot f_{ck}^{2/3}.$$

Model II considers the effects caused by diagonal cracking, which in practice reduce the inclination of the concrete strut and, as consequence, the contribution from concrete. In this model, the Brazilian code allows the angle of the strut to vary between 30° and 45° , thus the value of $V_{R,c II}$ shall be calculated in accordance with Equation 10. In this case, the concrete contribution is taken as a function of the applied shear force (V_{sd}), which is calculated by an iterative process. The contribution from the stirrups ($V_{R,cs}$) is calculated using Equation 11 and the maximum shear resistance ($V_{R,max II}$) shall be obtained using Equation 12.

$$V_{R,cs, II} = V_{R,c II} + V_{R,s II} \quad (9)$$

$$V_{R,c II} = V_{c0} \cdot \frac{V_{R,max II} - V_{sd}}{V_{R,max II} - V_{c0}} \leq V_{c0} \quad (10)$$

$$V_{R,s II} = \frac{A_{sw}}{s} \cdot 0.9 \cdot d \cdot f_{yw} \cdot (\cot \theta + \cot \alpha) \cdot \sin \alpha \quad (11)$$

$$V_{R,max II} = 0.54 \cdot \left(1 - \frac{f_c}{250} \right) f_c \cdot b_w \cdot d \sin^2 \theta \cdot (\cot \alpha + \cot \theta) \quad (12)$$

ACI 318 (2014)

The model recommended by ACI assumes a fixed angle for the concrete strut of 45° . The shear resistance of members without transverse reinforcement is defined in Equation 13, where M and V are the applied bending moment and shear force in the section. In this equation, $\sqrt{f_c}$ shall not exceed 8.3 MPa.

$$V_{R,c} = \left(0.16 \cdot \sqrt{f_c} + 17 \cdot \rho_l \cdot \frac{V \cdot d}{M} \right) b_w \cdot d \leq 0.29 \cdot \sqrt{f_c} \cdot b_w \cdot d \quad (13)$$

In Equation 13, the term $(V \cdot d/M)$ can be replaced by d/a . Alternatively, the code assumes that for the majority of design cases the term $(\rho_l \cdot V \cdot d)/M$ can be taken as $0,1 \cdot \lambda \cdot \sqrt{f_c}$, yielding in the simpler version presented in Equation 14.

$$V_{R,c} = 0,17 \cdot \sqrt{f_c} \cdot b_w \cdot d \quad (14)$$

For reinforced concrete elements with transverse reinforcement, the shear resistance ($V_{R,cs}$) is calculated with Equation 15 and is defined by the sum of the contributions from concrete ($V_{R,c}$) and steel ($V_{R,s}$), the last one obtained with Equation 16, where f_{yw} is the yield stress of the stirrups, limited to 420 MPa. The maximum shear resistance is calculated with Equation 17.

$$V_{R,cs} = V_{R,c} + V_{R,s} \quad (15)$$

$$V_{R,s} = \left(\frac{d}{s} \right) \cdot A_{sw} \cdot f_{yw} \cdot (\sin \alpha + \cos \alpha) \quad (16)$$

$$V_{R,max} = 0,66 \cdot \sqrt{f_c} \cdot b_w \cdot d \quad (17)$$

Flexural Capacity of Reinforced Concrete Members

Codes of practice like ABNT NBR 6118 (2014) or Eurocode 2 (2004) among others present recommendations to calculate the flexural capacity of reinforced concrete members. In these cases, the simplified theory proposed is based on the following assumptions: Bernoulli hypothesis of plane sections is valid; perfect compatibility of strains between concrete and steel; tensile resistance of concrete shall be neglected in the ultimate limit state; the stress distribution in concrete can be assumed as a parabola-rectangle diagram, which can be replaced by a constant rectangle, defined as presented in

Figure 7. Considering the recommendations presented by ABNT NBR 6118 (2014), the flexural resistance of reinforced concrete members can be calculated using Equations 18 to 20.

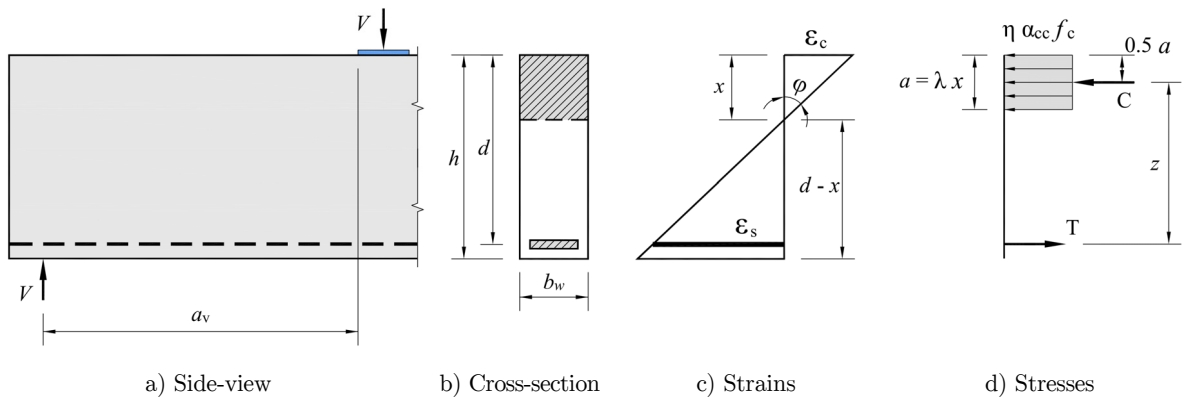

Figure 7: Assumed strain and stresses distribution in the ultimate limit state.

$$C = T \quad \therefore \quad \eta \cdot \alpha_{cc} \cdot f_c \cdot b_w \cdot a = A_{sf} \cdot f_{ys} \quad \therefore \quad a = \frac{A_{sf} \cdot f_{ys}}{\eta \cdot \alpha_{cc} \cdot f_c \cdot b_w} \quad (18)$$

$$M_{flex} = A_{sf} \cdot f_{ys} \cdot (d - 0.5 \cdot a) \quad (19)$$

$$V_{flex} = \frac{M_{flex}}{a_v} \quad (20)$$

Where:

η is a constant, assumed as 1 in case the breadth of the cross-section, measured parallel to the neutral axis does not decrease from this point to the more compressed edge, and 0.9 in case it does decrease; α_{cc} is assumed as 0.85 in design cases where $f_c \leq 50$ MPa. In cases where long term effects of concrete are neglected, like of short-time tests, it can be assumed as 0.95;

f_c is the concrete compressive strength;

b_w is the width of the cross section;

a is the depth of the concrete stress block;

A_{sf} is the area of flexural reinforcement;

f_{ys} is the yield stress of the flexural reinforcement;

a_v is the shear span.

3 EXPERIMENTAL PROGRAM

Eight tests on reinforced concrete wide beams were carried at Federal University of Para, Brazil. All the specimens were 500 mm wide and 2,500 mm long and were submitted to four-point bending tests. The thickness of the first three was 190 mm and all others were 210 mm thick.

The thickness and the flexural reinforcement ratio adopted in the tested wide beams are representative of the ranges observed in column strips in flat slab buildings. Also, all the specimens were designed to fail by shear. The effectiveness of the unconnected "W" stirrups was evaluated through comparison with results of tests on reference beams, which were cast without shear reinforcement, and based on tests on wide beams with closed vertical stirrups. Vertical and inclined "W" stirrups were tested. The main variable in these tests was the shear span (a_v). Tests were carried on short-span ($a_v/d \approx 2.0$) wide-beams, where arching action is significant, and slender wide-beams ($a_v/d > 2.0$), where shear is transferred mainly by truss mechanisms. The other variable evaluated were the ratio of flexural (ρ_l) and shear (ρ_w) reinforcement. The name of the specimens was defined considering the code A – B – C, where:

- A: refers to the type of shear reinforcement, where R denotes the reference specimens without shear reinforcement, C relates to specimens with closed vertical stirrups and W represents the specimens with unconnected "w" stirrups;
- B: refers to the shear span to effective depth (a_v/d) ratio and can assume the values of 2 or 4;
- C: refers to the angle between the shear reinforcement and the longitudinal axle of the beam. 90 represents beams with vertical stirrups and 45 represent the beam with inclined stirrups.

Two wide beams without shear reinforcement (R-2 and R-4) were tested and served as reference for those with closed stirrups (C-2-90 and C-4-90) and with the unconnected "w" stirrups (W-2-90a, W-2-90b, W-4-90 and W-4-45). The shear span values were defined in order to check if the performance of the unconnected "w" stirrups is influenced by the shear transfer mechanisms. Short-span beams ($a_v/d \approx 2$) and slender beams ($a_v/d \approx 4$) were tested. Table 1 presents the main features of these tests.

Series	Specimen ⁽¹⁾	h (mm)	d (mm)	a_v (mm)	a_v/d	f_c (MPa)	ρ_l ⁽²⁾ (%)	ρ_w ⁽³⁾ (%)	α (°)
1 st	R-2		158		2.1		1.71	---	---
	C-2-90	190	161	325	2.0	40	1.68	0.185	90
	W-2-90a		162		2.0		1.67	0.149	90
W-2-90b		182	400	2.2		2.42	90		
2 nd	R-4		176		3.8		2.50	---	---
	C-4-90	210	178	670	3.8	33	2.47	0.139	90
	W-4-90		182		3.7		2.42		90
	W-4-45		182		3.7		2.42	0.111	45

⁽¹⁾ the width b_w was 500 mm in all tests.

⁽²⁾ calculated as $A_{s,f}/b_w \cdot d$ and with.

⁽³⁾ calculated as $A_{s,w}/b_w \cdot s$.

Table 1: Characteristics of tested elements.

The concrete was made with Portland-composite cement with pozzolan addition, natural sand and rolled pebble with a maximum diameter of 9.5 mm. The compressive strength of concrete was determined by tests on 100 x 200 mm control cylinders tested at the same day of the wide beams in accordance with ABNT NBR 5739 (2007). The wide beams and the control cylinders were cured with

wet covering during seven days and after it, they were stored until the day of the tests at ambient weather conditions.

Samples from the steel bars used as flexural and shear reinforcement were submitted to tensile tests in accordance with the ABNT NBR 6892 (2013). Specimens with the smallest shear span ($a_v/d \approx 2$) had 11 bars with diameter of 12.5 mm ($f_{ys} = 515$ MPa and $\epsilon_{ys} = 2.69\%$) as flexural reinforcement ($\rho_l \approx 1.70\%$). In the remaining specimens ($a_v/d \approx 4$) the flexural reinforcement was made with 7 bars with 20.0 mm diameter ($f_{ys} = 526$ MPa and $\epsilon_{ys} = 2.54\%$), resulting in a flexural reinforcement ratio $\rho_l \approx 2.45\%$.

In type C beams, groups of closed stirrups were combined in order to have six vertical legs in each shear reinforcement layer. They were installed embracing the flexural rebars. The “w” stirrups (type W beams) were joined in a prefabricated cage and were positioned between the upper and lower flexural rebars. Each shear reinforcement layer was formed by two vertical legs and four 45° inclined legs. The prefabricated cages were used in vertical ($\alpha = 90^\circ$) and inclined ($\alpha = 45^\circ$) arrangements. In both cases, the shear reinforcements were manufactured using 4.2 mm bars ($f_{ys} = 679$ MPa and $\epsilon_{ys} = 4.67\%$).

The load was applied at fixed stages, and between each loading step, short time intervals were made in order to observe the cracking pattern and measure vertical displacements and strains on concrete and on flexural and shear rebars. Figure 8 and Table 2 show details about the flexural and shear reinforcement. Strain gauges were used to measure the compressive strains in the top surfaces of the wide beams, placed in the middle of their span. In the case of the flexural and shear reinforcement, strains were measured by pairs of strain gauges, installed at opposite ends of diameters of the bars. Vertical displacements were measured by dial gauges placed in the middle of the beams span. Figure 8 also presents details of the instrumentation used in tests. Figure 9 show photos of different stages of the experimental program.

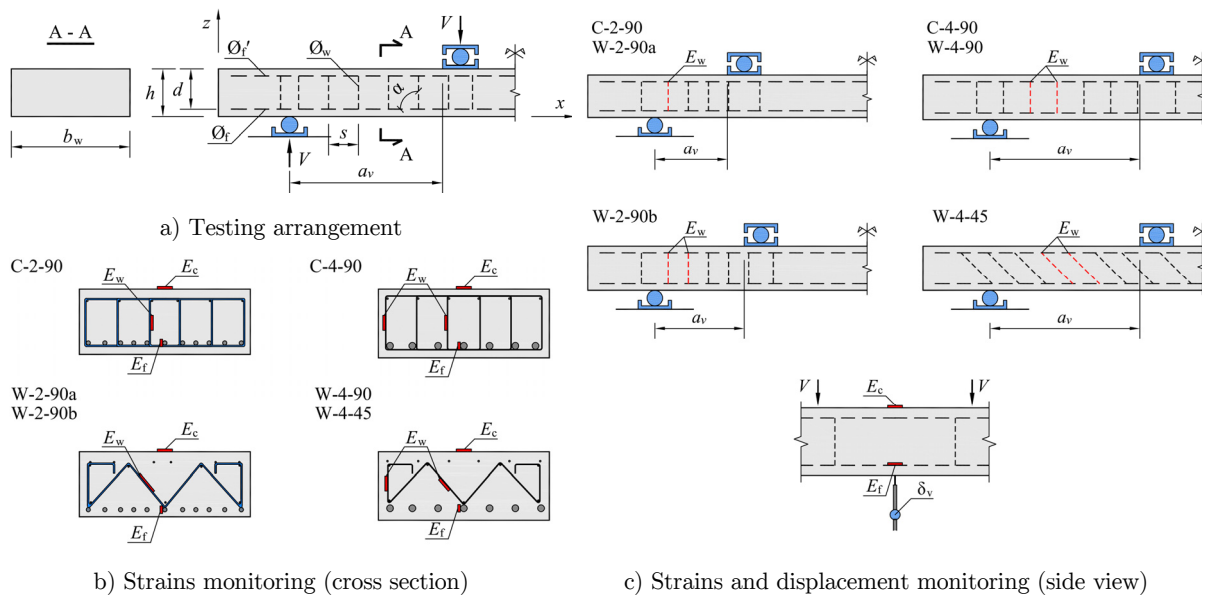

Figure 8: Illustration of the testing system and of monitoring of strains and displacements.

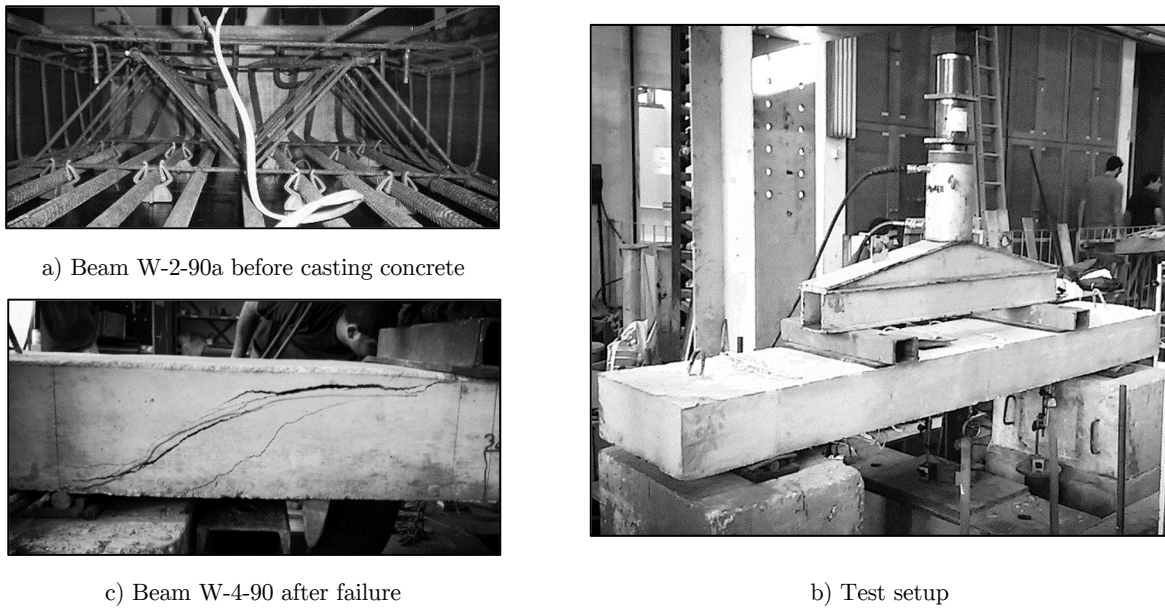

Figure 9: Photos of different stages of the experimental program.

Series	Specimen	Flexural Reinforcement					Shear Reinforcement					
		ϕ_f (mm)	f_{ys} MPa	ϵ_{ys} ‰	$n_f^{(1)}$	A_{sf} (mm ²)	ϕ_w (mm)	f_{yw} MPa	ϵ_{yw} ‰	$n_w^{(2)}$	A_{sw} (mm ²)	s (mm)
1 st	R-2						---	---	---	---	---	---
	C-2-90	12.5	515	2.69	11	1,350				6	83	
	W-2-90a						4.2	679	4.67	4.8 ⁽³⁾	67	90
2 nd	W-2-90b											
	R-4						---	---	---	---	---	---
	C-4-90	20.0	526	2.54	7	2,199				6	83	
	W-4-90						4.2	679	4.67	4.8 ⁽³⁾	67	120
	W-4-45											45

⁽¹⁾ n_f is the number of flexural bars in tensioned zone.

⁽²⁾ n_w is the number of legs of shear reinforcement.

⁽³⁾ “w” stirrups had 2 vertical legs and 4 legs inclined at 45° in the x-y plane. The value presented corresponds to the equivalent number of vertical legs for wide beams with “W” stirrups.

Table 2: Characteristics of flexural and shear reinforcement.

4 RESULTS

The crack morphology and progression was similar, regardless of the shear reinforcement type. All tests failed due to shear and Figure 10 presents the cracking pattern after failure. In early load stages, initial pure flexural cracks occurred and they spread towards the shear span as the load was increased. For short-span beams, the arching action was clearly observed once that the critical shear crack emerged and developed stably in an intermediate loading stage (0.5 to 0.6 of V_u). In slender beams with unconnected stirrups, after failure, horizontal cracks were observed, what can be an indicative of delamination.

The load-deflection response was monitored as shown in Figure 7c and was affected by the type of shear reinforcement. Wide beams with “W” stirrups had a stiffer response. This may result from the fact that additional longitudinal bars are used to assist in the anchoring of the “W” stirrups, which even without appropriate detailing can contribute in the flexural response. Figure 11 presents the flexural response of the tested specimens.

In the first three tests (R2, C-2-90 and W-2-90a), only the flexural bar in the middle of the cross section was monitored. In all others, the strains in the bars in the middle and in the corner of the cross section were measured and, in such cases, results shown in Figure 12a represent average values. For short span beams, the flexural rebars of all but the reference beam (R-2) yielded. The highest flexural reinforcement ratio used in the slender beams resulted in shear failures without yielding of the bending rebars.

The flexural response of the beams, measured in terms of strains in the flexural bars, was similar in all tests, regardless of the type of shear reinforcement. However, the strains in the concrete surface were different after cracking for beams with closed stirrups and for those with unconnected “W” stirrups, as show in Figure 12b. As previous mentioned, those with “W” stirrups seem to have a stiffer response. In the case of W-2-90b the highest flexural reinforcement ratio can explain the stiffer response, but this was also observed for the other three beams with unconnected stirrups. This may be a consequence of the contribution of the extra longitudinal bars used to improve the anchorage of the “W” stirrups.

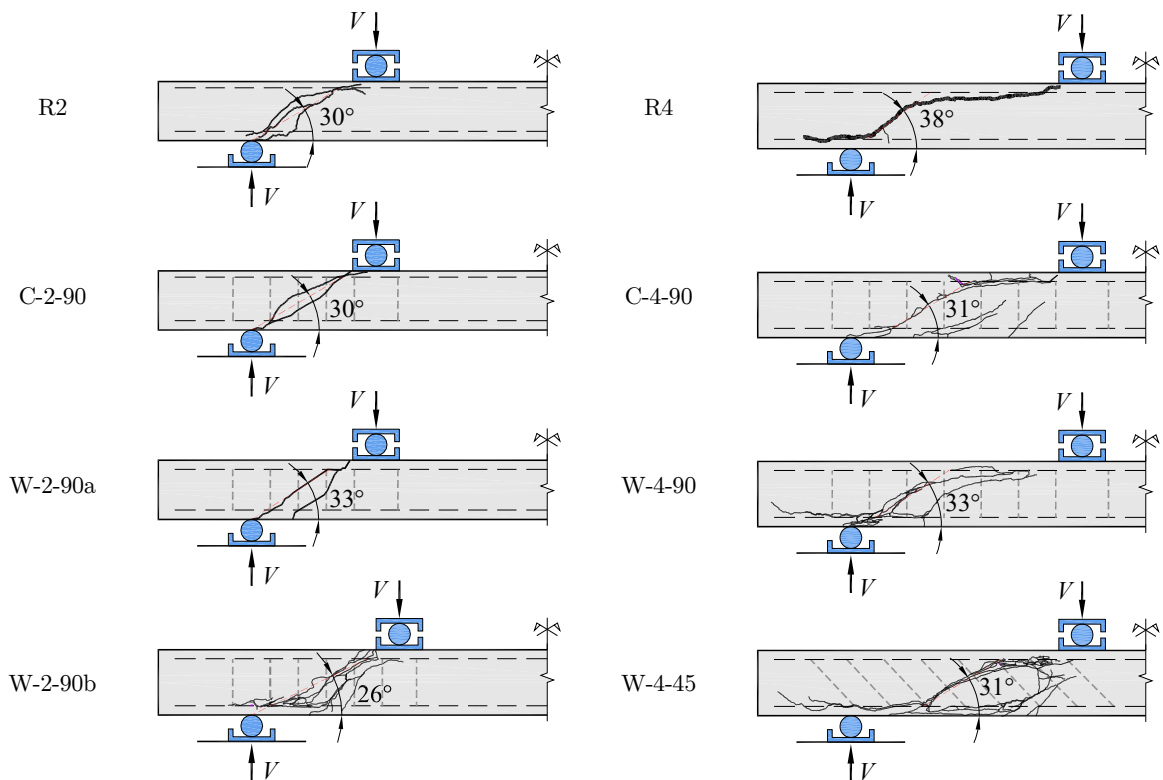

Figure 10: Cracking pattern after failure.

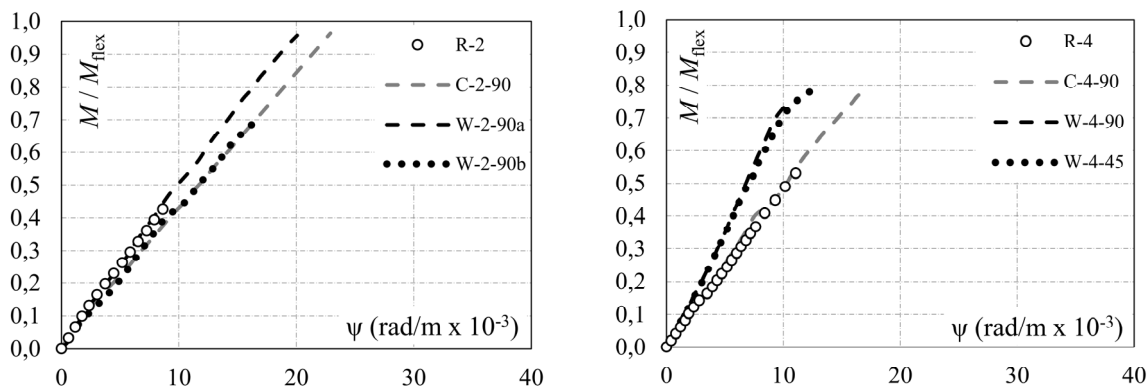
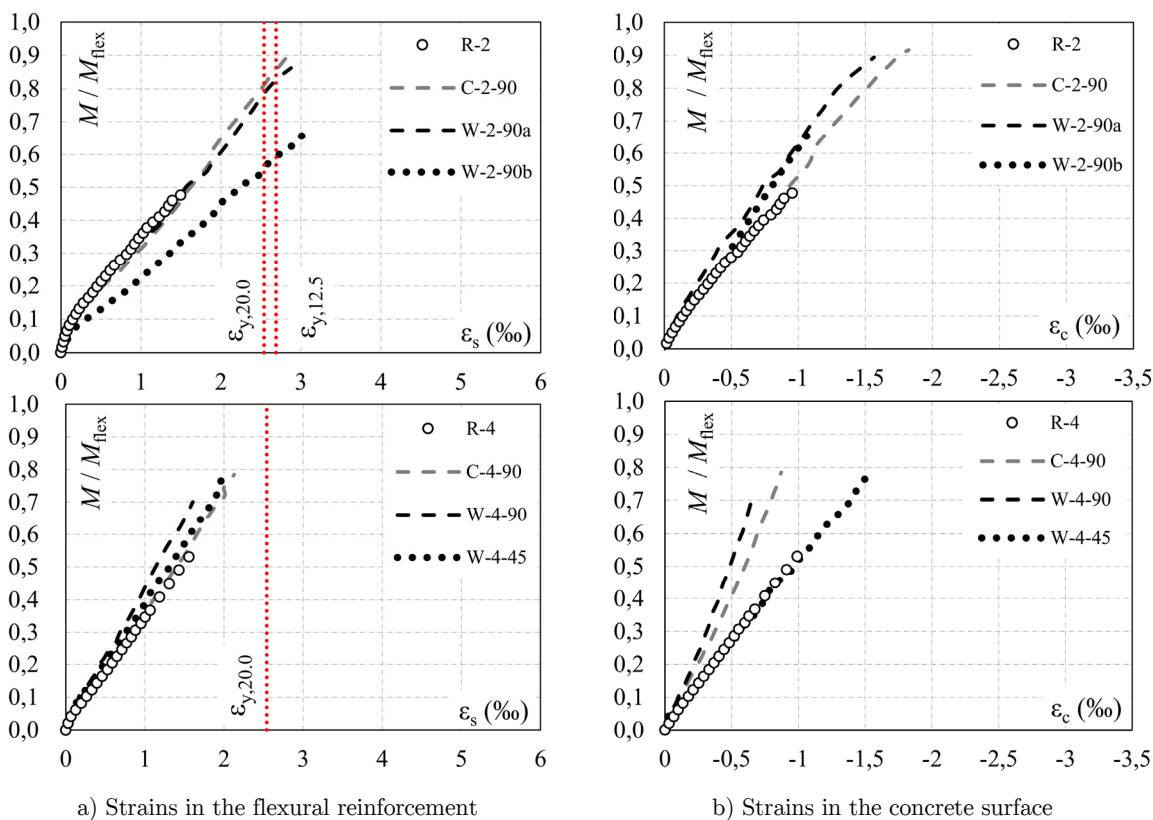

Figure 11: Flexural response of tested specimens.



a) Strains in the flexural reinforcement

b) Strains in the concrete surface

Figure 12: Strains on flexural steel and on concrete surface.

Figure 13 presents results of tensile strains measured in the shear reinforcement of the tested wide beams. Results from tests on wide beams C-4-90 and W-4-45 were selected to illustrate the behaviour observed in tests. The deformations were measured at short-time intervals during loading stages and were stopped just before the failure of specimens. In general, the stirrups respond only after being crossed by shear cracks. At failure, the behaviour and the strain values measured were similar for

wide beams with both closed and unconnected stirrups. For almost all cases, the maximum strains measured in the shear reinforcement were below the yield strain as shown in Figure 12a. The exception was the wide beam W-4-45, with inclined unconnected “W” stirrups, in which the strains in the inner legs were above the yield strain.

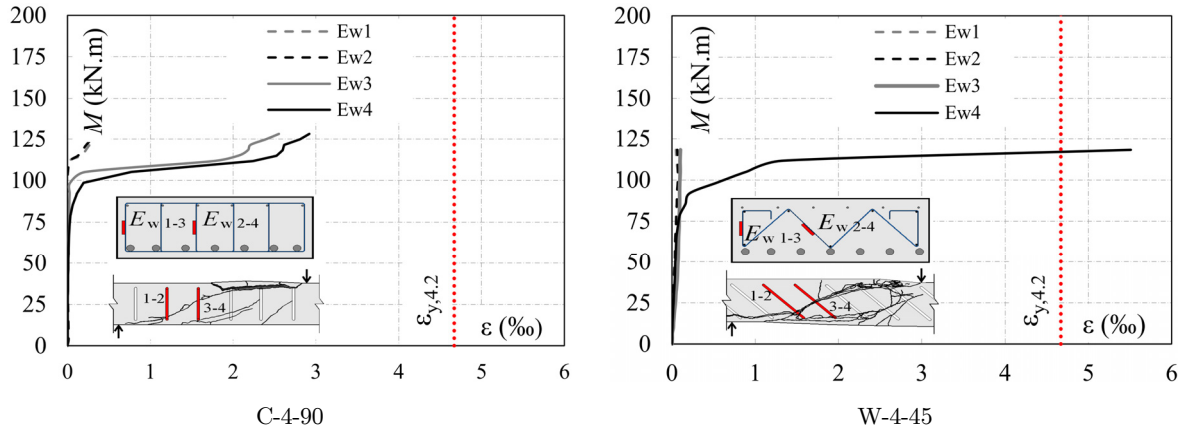

Figure 13: Strains on the shear reinforcement.

Table 3 presents the ultimate shear force (V_{test}) and bending moment (M_{test}) measured on tests. It also compares the experimental results with the theoretical resistance predicted using: Models I and II from the Brazilian code NBR 6118 (V_{NBR-I} and V_{NBR-II}); the American design code ACI 318 (V_{ACI}); and the European design code (V_{EC2}). It also presents results of a modified version from Model II of NBR 6118 (V_{NBR-II}^*) done to take into account for the arching action. The Brazilian code presents provisions for this in cases where $a_v / d \leq 2.0$. In this proposal, this limit was increased to 2.5, calculated as shown in Equation 21.

$$V_{NBR-II}^* = V_{NBR-II} \cdot (2.5 \cdot d/a_v) \tag{21}$$

All specimens showed higher shear resistance than the values theoretically predicted by codes. For short-span beams, the unconnected “W” stirrups had great efficiency, providing resistance increments of up to 83% if compared to the reference beam. These results are noteworthy, since that, even with four in-plane inclined legs, their performance was greater than the one from closed vertical stirrups.

For slender beams, the performance of the unconnected stirrups decreased. The absence of the favourable arching action observed in the short-span tests demanded more contribution from the shear reinforcement and the worst anchorage conditions limited the resistance gains. The wide beams W-4-90 and W-4-45 registered resistance increments of 44% and 54%, respectively, if compared to R-4, against an increment of up to 64% in specimen C-4-90. Nevertheless, if it is considered that the wide beams with unconnected “W” stirrups had shear reinforcement ratio 20% smaller than those with closed vertical stirrups, these results are also encouraging.

Specimen	d (mm)	a (mm)	f_c (MPa)	ρ_f (%)	ρ_w (%)	V_{test} (kN)	M_{test} (kN.m)	V_{flex} (kN)	V_{test} / V_{NBR-I}	V_{test} / V_{NBR-II}	$V_{test} / V_{NBR-II}^{(3)}$	V_{test} / V_{ACI}	V_{test} / V_{EC2}
R-2	158			1.71	---	166.7	54.2	298.8	1.43	1.43	1.18	1.96	1.43
C-2-90	161	325	40	1.68	0.185	280.7	91.2	305.3	1.51	1.32	1.07	1.88	1.53
W-2-90a	162			1.67		304.0	98.8	307.4	1.75	1.56	1.25	2.21	2.06
W-2-90b	182	400		2.42	0.149	301.6	120.7	419.9	1.68	1.49	1.31	2.07	1.66
R-4	176			2.50	---	129.9	87.0	240.3	1.14	1.14	1.14	1.51	1.01
C-4-90	178		33	2.47	0.139	212.8	142.6	243.8	1.24	1.10	1.10	1.53	1.13
W-4-90	182	670		2.42	0.111	186.7	125.1	250.7	1.14	1.03	1.03	1.42	1.20
W-4-45	182			2.42	0.158	200.5	134.3	250.7	1.10	1.02	1.02	1.34	1.30
Mean									1.37	1.26	1.14	1.74	1.42
COV									18.8%	17.2%	9.2%	18.9%	23.6%

Table 3: Test results and comparisons with design standards

Figure 14 illustrates the comparisons between the theoretical previsions and the experimental results. It shall be highlighted that no unsafe estimates were observed, indicating that the current code provisions could be used to design concrete members with unconnected “W” stirrups. From all the evaluated provisions, Eurocode 2 had the worst performance, showing the highest coefficient of variation ($\approx 30\%$) and underestimating significantly the shear resistance of the wide beams with stirrups once it ignores the contribution from concrete in such cases. ACI’s predictions were also over conservative as shown in Table 3 and Figure 14. Model II from the Brazilian code showed the best performance in terms of the evaluated code provisions.

Considering only these test results, a better correlation between the experimental results and the theoretical predictions from Model II of the Brazilian code could be achieved if the range to consider the positive contribution of the arch effect was extended to shear span to effective depth ratios of $a_v/d < 2.5$. It would be necessary to analyse a wider sample space to actually evaluate the adequacy of this change.

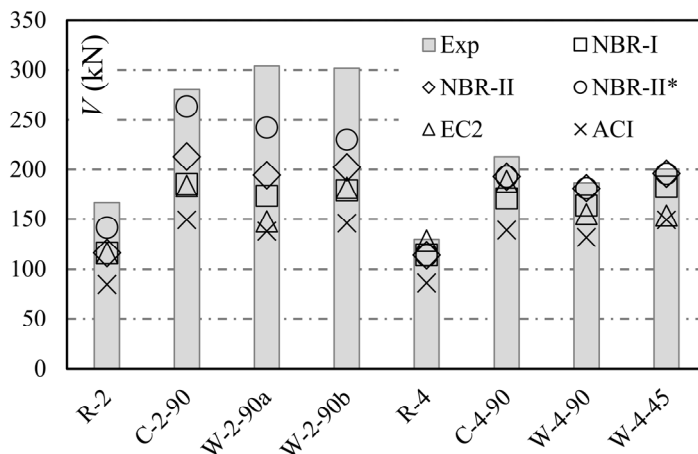

Figure 14: Comparison between experimental and theoretical results.

5 CONCLUSIONS

This paper reviewed technical and constructive aspects of the use of shear reinforcement in slab-column connections. A new type of shear reinforcement was presented, which has the potential to be an advantageous constructive solution if compared to the shear reinforcement currently used in practice. To evaluate the mechanical efficiency of this new shear reinforcement system, a series of eight experimental tests was carried in reinforced concrete wide beams, idealized to represent the column strips in flat slab buildings.

In general, both the response and shear resistance of the structural elements with unconnected “W” stirrups were similar to those elements with vertical closed stirrups. Increments of shear resistance of up to 84% were achieved with the use of the “W” stirrups, indicating that they consist of a shear reinforcement system with high potential for use in slab-column connections.

The experimental results were compared with the theoretical predictions obtained using the recommendations presented by the Brazilian, American and European design standards. No unsafe shear resistance provisions were obtained, indicating that the current recommendations could be used for the design of reinforced concrete members with unconnected “W” stirrups as shear reinforcement.

Although a greater number of tests is necessary to improve their performance and to guarantee their efficiency as shear reinforcement for flat slabs, the results already available and presented in this paper are noteworthy and shall encourage more research efforts.

Acknowledgments

The authors are grateful to the Brazilian Research Funding Agencies CAPES (Higher Education Co-ordination Agency), CNPq (National Council for Scientific and Technological Development) and FAPESPA (Research Funding Agency of Para) for their support throughout this research. They also would like to thank the Applied Structural Modelling Group (NUEMA) and the Amazon Development Centre for Engineering (NDAE) for the infrastructure used in these tests.

References

- ABNT NBR 5739 (2007). Concrete - Compression test of cylindrical specimens - method of test, Brazilian Technical Standards Association, Rio de Janeiro.
- ABNT NBR 6118 (2014). Design of concrete structures — Procedure, Brazilian Technical Standards Association, Rio de Janeiro.
- ABNT NBR 6892 (2013). Metallic materials — Tensile testing Part 1: Method of test at room temperature, Brazilian Technical Standards Association, Rio de Janeiro.
- ACI 318 (2014). Building Code Requirements for Structural Concrete, American Concrete Institute, Farmington Hills, Michigan.
- Anderson, J. L. (1963). Punching of Concrete Slabs with Shear Reinforcement, Royal Institute of Technology, Bulletin No. 212, KTH Stockholm, Switzerland.
- Andrade, J. L. S. (2000). Estudo Experimental da Inclinação de Estribos Abertos em Lajes Cogumelo de Concreto Armado. MSc. Dissertation, Universidade de Brasília, Brasília, Brazil, 142p. (in Portuguese).
- Beutel, R. and Hegger, J. (2000). Punching Behaviour of Shear Reinforced Flat Slabs at Interior Columns: Effective and Economic Shear Systems. International Workshop on Punching Shear Capacity on RC Slabs, Proceedings, Stockholm, Sweden, pp. 171-180.

- Beutel, R. and Hegger, J. (2002). The Effect of Anchorage on the Effectiveness of the Shear Reinforcement in the Punching Zone. *Cement & Concrete Composite*, Vol. 24, No.6, pp 539-549.
- Broms, C. E. (2000). Elimination of Flat Plate Punching Failure Mode, *ACI Structural Journal*, V. 97, No 1, pp. 94-101.
- Caldentey, A. P., Lavaselli, P. P., Peiretti, H. C., Fernández, F. A. (2013). Influence of stirrup detailing on punching shear strength of flat slabs. *Engineering Structures*, Vol. 49, pp 855-865.
- Chana, P. S. (1993). A Prefabricated Shear Reinforcement System for Flat Slabs. *Proceedings of the Institution of Civil Engineers: Structures and Buildings*, Vol. 99, No.3, pp 345-358.
- Dilger, W., Ghali, A., Shear Reinforcement for Concrete Slabs, *Journal of Structural Engineering*, ASCE, Vol. 107, 1981, pp. 2403-2420.
- Eligehausen, R. and Balogh, T. (1995). Behaviour of Fasteners Loaded in Tension in Cracked Reinforced Concrete. *ACI Structural Journal*, Vol. 92, No 3, pp. 365-379.
- Elstner, R. C. and Hognestad, E. (1956). Shearing Strength of Reinforced Concrete Slabs. *Journal of the American Concrete Institute*, Vol. 53, No. 7, pp. 29-58.
- ETA 13/0521 (2013). Filigran FDB II Punching Shear Reinforcement, European Technical Approval, Klieken, Germany.
- Eurocode 2 (2004). Eurocode 2: Design of Concrete Structures—Part 1-1: General Rules and Rules for Buildings. CEN, EN 1992-1-1, Brussels, Belgium.
- Ferreira, M. P., Melo, G. S. S., Regan, P. E. and Vollum, R. L (2014). Punching of Reinforced Concrete Flat Slabs with Double-Headed Shear Reinforcement, *ACI Structural Journal*, Vol. 111, No. 2, pp 363-374.
- Furche, J. (1997). Elementdecken im Durchstanzbereich von Flachdecken. *Betonwerk+Fertigteiltechnik*. pp. 96-104.
- Furche, J., Bauermeister, U., Flachdecken in Elementbauweise mit Gitterträgern: Hinweise zur Anwendung nach Eurocode 2, *Beton- und Stahlbetonbau*, Vol. 109, No. 11, 2014, pp. 783-792.
- Gomes, R. B. and Andrade, M. A. S. (2000). Does a punching shear reinforcement need to embrace a flexural reinforcement of a RC flat slab?, *International Workshop on Punching Shear Capacity of RC Slabs*, KTH Stockholm, June, Proceedings pp 109-117.
- Gomes, R. B., and Regan, P. E. (1999). Punching Resistance of RC Flat Slabs with Shear Reinforcement. *Journal of Structural Engineering*, Vol. 125, No. 6, pp 684-692.
- Graf, O. (1938). Versuche über die Widerstandsfähigkeit von allseitig aufliegenden dicken Eisenbetonplatten unter Einzellasten. *Deutscher Ausschuss für Eisenbeton*, Heft 88, Berlin, 22p.
- Langohr, P., Ghali, A., Dilger, W. Special Shear Reinforcement for Concrete Flat Plates. *Journal of the American Concrete Institute*, 1976, pp. 141-146.
- Melo, G. S. S., Coelho, A. E. G. and Oliveira, D. R. C. (2000). RC flat slabs with inclined stirrups as shear reinforcement. *International Workshop of Punching Shear Capacity of RC Slabs*, KTH, Stockholm, June, Proceedings pp 155-162.
- Park, H. G., Ahn, K. S., Choi, K. K., Chung, L., Lattice shear reinforcement for slab-column connections, *ACI Structural Journal*, Vol. 104, No. 3, 2007, pp. 294-303.
- Pilakoutas, K., Li, X., Alternative Shear Reinforcement for Reinforced Concrete Flat Slabs, *Journal of Structural Engineering*, Vol. 129, No. 9, 2003, pp. 1164-1172.
- Regan, P. E. (1993). Tests of connections between flat slabs and edge columns, *School of Architecture and Engineering*, University of Westminster, July.
- Regan, P. E. (2000). Shear Reinforcement of Flat Slabs, *International Workshop on Punching Shear Capacity of RC Slabs - Proceedings*, TRITA-BKN, Bulletin 57, pp. 99-107.

- Regan, P. E. and Samadian, F. (2001). Shear Reinforcement against Punching in Reinforced Concrete Flat Slabs. *The Structural Engineer*, Vol. 79, No. 10, pp. 24-31.
- Seible, F., Ghali, A. and Dilger, W. Preassembled Shear Reinforcing Units for Flat Plates. *Journal of the American Concrete Institute*, Vol. 77, No. 1, 1980, pp. 28-35.
- Trautwein, L. M. (2001), *Punção em Lajes Cogumelo de Concreto Armado com Armadura de Cisalhamento tipo Stud Interno e Tipo Estribo Inclinado*. MSc Dissertation, Universidade de Brasília, Brasília, Brazil, 185p (in Portuguese).
- Trautwein, L. M., Bittencourt, T. N.; Gomes, R. B.; e Bella, J. C. D. (2011). Punching Strength of Flat Slabs with Unbraced Shear Reinforcement. *ACI Structural Journal*, Vol. 108, No. 2, pp. 197-205.
- Yamada, T., Nanni, A., Endo, K., Punching shear resistance of flat slabs: influence of reinforcement type and ratio, *ACI Structural Journal*, Vol. 88, No. 4, 1992, pp.555-564.